

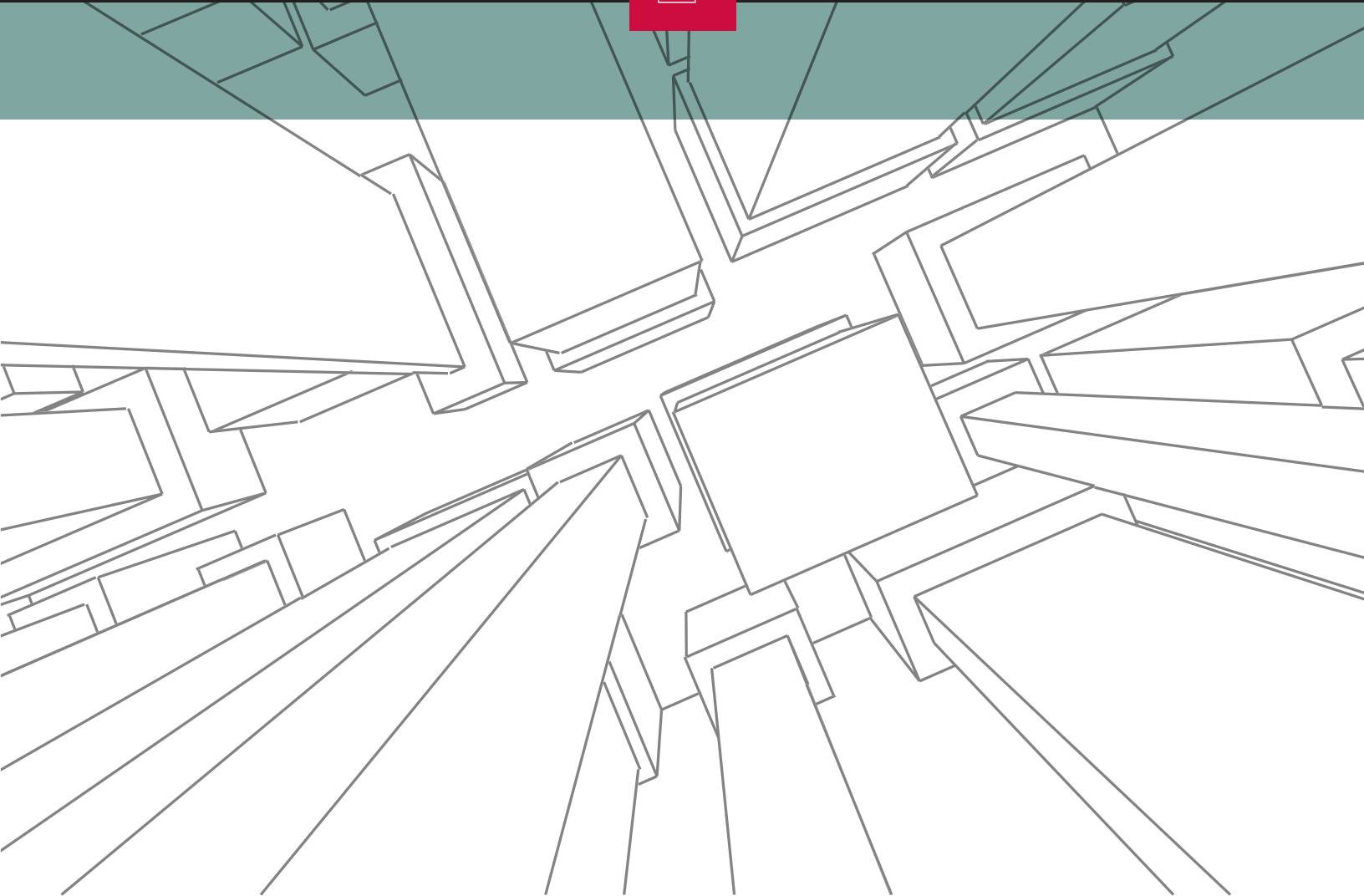

LEGACY VOLT

PLANNING GUIDE



 **LEGACY VOLT
PLANNING GUIDE**

This planning guide was created to assist home builders, architects, contractors, home owners and elevator professionals in planning for a residential elevator to meet the requirements of CAN/CSA B44 and ASME A17.1 National Elevator Code for residential elevators. It will provide you with nominal dimensions and specifications which are required for the initial planning stages of your project. The following guide is applicable to our Legacy Volt models only.

It is important to know and to adhere to all regulations pertaining to the installation and use of elevators to ensure that the product is used correctly and safely. Federal Elevator strongly recommends the following:

- That the proper code authority having jurisdiction in the area where the elevator will be installed be contacted directly,
- That the person responsible for the project is familiar with all legal requirements governing the installation and the use of elevators in private residences.

Questions?

Please contact us at **(905)458-4015** or at **sales@federalevator.com**. All projects are issued a serial number beginning with F- and followed by four numbers. Please reference this number when communicating with us.



TABLE OF CONTENTS

1	General Specifications	10	Type A
2	Preparatory Work by Others	11	Right Accordion Gate
3	Warranty	12	Left Accordion Gate
3	Owner's Instruction & Manual	13	Right Bi-Fold Gate
4	Elevator Components	14	Left Bi-Fold Gate
5	Pit Construction	15	Type B
6	Rail Bracket Detail Roped	16	Accordion Gate
7	Rail Forces	17	Bi-Fold Gate
8	Machine Room	18	Type C
9	Home Elevator Safety Clearance – ¾" x 4" Rule	19	Accordion Gate
		20	Type D
		21	Accordion Gate
		22	Type E
		23	Accordion Gate – Centered Entrance
		24	Left Accordion Gate
		25	Right Accordion Gate
		26	Bifold Gate – Centered Entrance



GENERAL SPECIFICATIONS

RESIDENTIAL ELEVATOR	
Load Capacity	1,000 lbs. (453 kg.)
Rated Speed	36 feet per minute (0.18 m/s) (Nominal)
Power Supply	230 volt, single phase, 30 amps
Drive Systems	Top winding drum (contact our office for bottom winding drum)
Cab Sizes (Other custom sizes available)	36" x 48" (914.4 mm x 1219 mm)[Standard] 40" x 54" (1016 mm x 1372 mm) 36" x 54" (914.4 mm x 1372 mm) 42" x 60" (1067 mm x 1524 mm) 36" x 60" (914.4 mm x 1524 mm)
Maximum Travel	32 ft. (9.75 m.)
Cab Door	Manual Accordion Gate (Automatic Accordion Door, Bifold Door optional)
Maximum Number of Stops	6 stops
Pit Depth Required	8" (203 mm) Minimum
Overhead Clearance	Minimum overhead for a bottom drum unit is 96" Minimum overhead for an overhead drum unit is 103"
Control System	Automatic Push Button or Constant Pressure
Floor Selection	Magnetic Selector
Flooring Material	Plywood (Floor to be finished by customer after elevator is installed)
Control Panel Finish	Stainless Steel (standard) Brass, Antique Brass, Matte Black and others (optional)
Hall Station Finish	Stainless Steel (standard) Brass, Antique Brass, Matte Black and others (optional)
Cab Panel Finish	Unfinished Maple, Unfinished Oak Veneer, Unfinished MDF
Lighting Supply	110 volt, 60 Hz, 15 amps
Legacy Volt Standard Features	<ul style="list-style-type: none"> ■ Automatic Timed ON/OFF Cab Lighting ■ Stainless Steel Illuminated Hall Buttons ■ Digital Floor Indicator in Cab (optional) ■ Emergency Battery Powered Lighting ■ Emergency Stop Button in Cab ■ Emergency Alarm Button in Cab ■ Solid Ceiling with LED Pot Lights ■ Stainless Steel Handrail ■ Stainless Steel Control Panel in car ■ Electromechanical locks at all door landings (Interlock) ■ Infrared Light Curtain if elevator is equipped with accordion doors or scissor gates ■ Overspeed Governor ■ Emergency Lowering ■ Phase Monitoring



PREPARATORY WORK BY OTHERS

The following preparatory work and items to accommodate the elevator shall be provided by others:

GENERAL

- An adequate enclosed, plumb and square hoistway with one load bearing wall and smooth interior surfaces to meet the load requirements on General Layout and all local codes.
- Measurements for travel, pit depth and overhead are very critical and must be within 1/4" (6mm).
- 8" (203 mm) minimum pit depth.
- A substantial, level pit floor slab to support loads indicated on General Layout.
- Pit water proofing or sump pump, if required (coordinate with elevator contractor for location).
- Adequate support for guide rail fastenings. Refer to General Layout for dimensions.
- 96" (2438 mm) minimum overhead for standard 8' cab with manual accordion gate (distance from floor at upper level to underside of roof). Please contact a representative if you are planning on adding a different cab gate or cab height.
- Barricades or guards shall be provided by others outside of every opening to the hoistway to protect other trades, building occupants or visitors as per the Occupational Health and Safety Act (OSHA). These guards and barricades to be erected, maintained and removed by others.

CONTROLLER ROOM

- Controller room to meet the requirement of local codes.
- A lockable Fused/Cartridge Type Disconnect Switch with auxiliary contact/switch to provide power for emergency light. Refer to General Layout for permanent power specifications and location of the disconnect switch.
- 110 VAC lighting supply and fused disconnect for cab lights. Refer to General Layout drawings for permanent power specifications and for location of disconnect switch.
- Main Disconnect Switch: 50Amp, 3 pole cartridge fuse type disconnect switch with an elevator rated auxiliary contact and type D fuses. (fuse size on drawings)

Make and part number:

1. Cutler Hammer: 1HD 321N with auxiliary contact DS 16CP
2. FPL: 1332 SN with auxiliary contact EIK-IAEV-W94
3. Siemens: ID321 with auxiliary contact MSSAK 116

- Cab Lighting: 30Amp, 1 Pole plug fuse type disconnect switch with 15A type D plug fuse (buss T15 or equal)

Make and part number:

1. Cutler Hammer: GP111N
2. FPL: 86211
3. Siemens: CFN 211

- Sleeves/Conduit for electrical wiring from controller room into hoistway as required.

ENTRANCES

- Doors, frames, and door hardware for all landings.

■ **NOTE: Do not construct the return walls on either side or above entrances until after the elevator is installed.**



WARRANTY

We will make good and/or replace, if necessary, any and all defects due to imperfect workmanship which may appear during the warranty period. These defects, and the repairs required, will be solely determined by Federal Elevator upon receiving at its place of business the piece deemed to be defective by the owner.

This warranty does not cover damages caused by normal wear and tear, accident, fire, unauthorized alterations, vandalism, wilful damage, negligence, acts of God, or other like causes. This warranty shall be considered null and void unless the elevator is maintained properly and consistently by a registered elevator mechanic in the province/state where the elevator is located. Such maintenance shall be performed in accordance with Federal Elevator's recommendations and the requirements of the province's acts and regulations.

Please refer to your signed contract to confirm the length of time your unit will be covered.

Note: Units purchased through one of our recognized Dealers will have the same terms as stated in the above warranty but with a time period of one (1) year ONLY. Customer may arrange for a longer warranty period however, this MUST be done prior to the unit being shipped from the Federal Elevator plant.

ATTENTION

- **Elevator hoistways are restricted spaces and only trained elevator tradespeople should access them.**
- **Access to hoistway by untrained persons can lead to severe injury or death.**
- **Any modifications or additions to hoistway performed without Federal Elevator involvement after the elevator is turned over will result in the voiding of any current warranties.**

OWNER'S MANUAL

Once installation is completed, the elevator contractor shall instruct the owner in the proper use, operation and maintenance requirements of the elevator. Instructions shall also include emergency procedures, safety rules and precautions. The elevator contractor shall also supply the owner with an Owner's Manual detailing the operating, safety, and maintenance procedures of the elevator.



ELEVATOR COMPONENTS

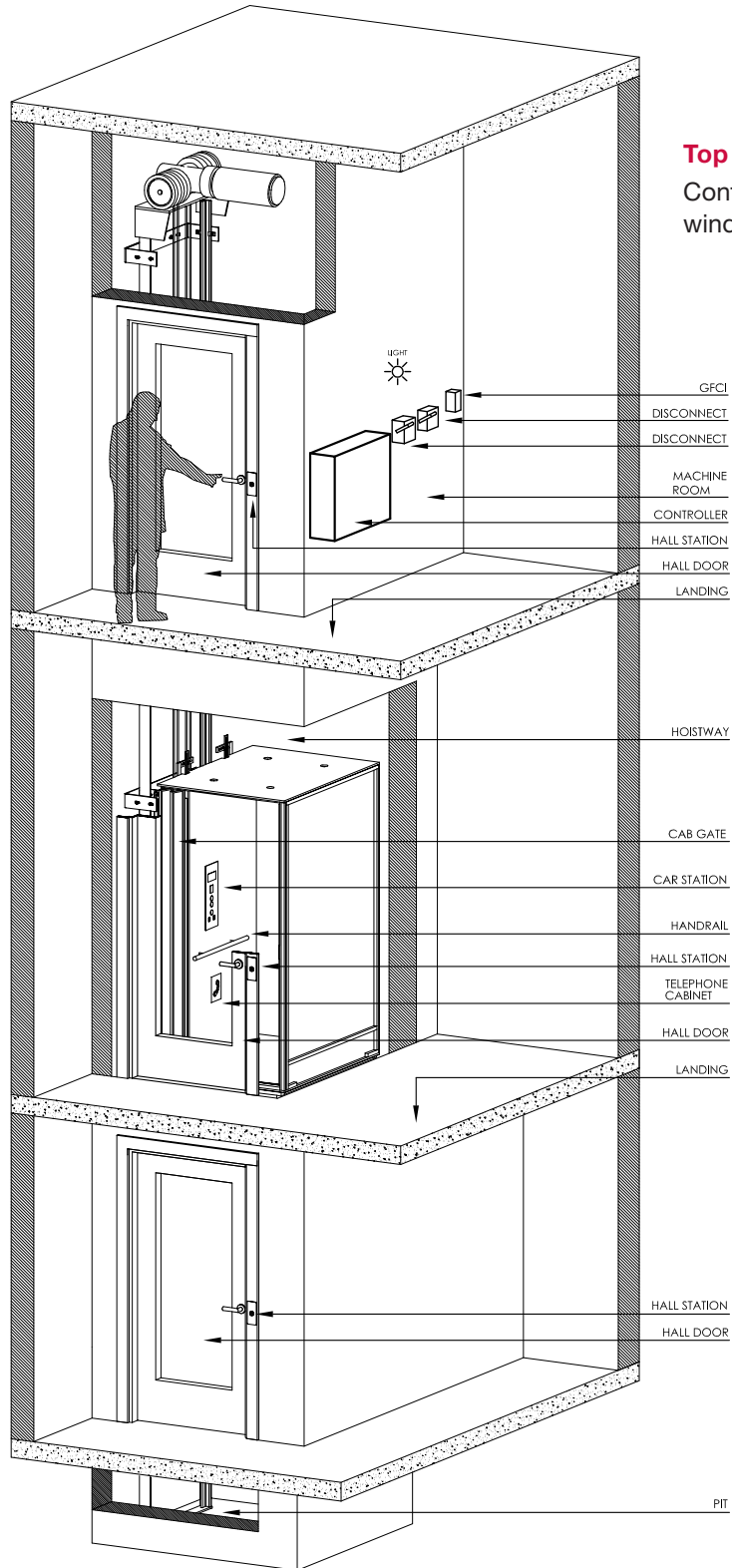

Top mounted Winding Drum

Contact office if bottom winding drum is required.

- GFCI
- DISCONNECT
- DISCONNECT
- MACHINE ROOM
- CONTROLLER
- HALL STATION
- HALL DOOR
- LANDING
- HOISTWAY
- CAB GATE
- CAR STATION
- HANDRAIL
- HALL STATION
- TELEPHONE CABINET
- HALL DOOR
- LANDING
- HALL STATION
- HALL DOOR
- PIT



PIT CONSTRUCTION

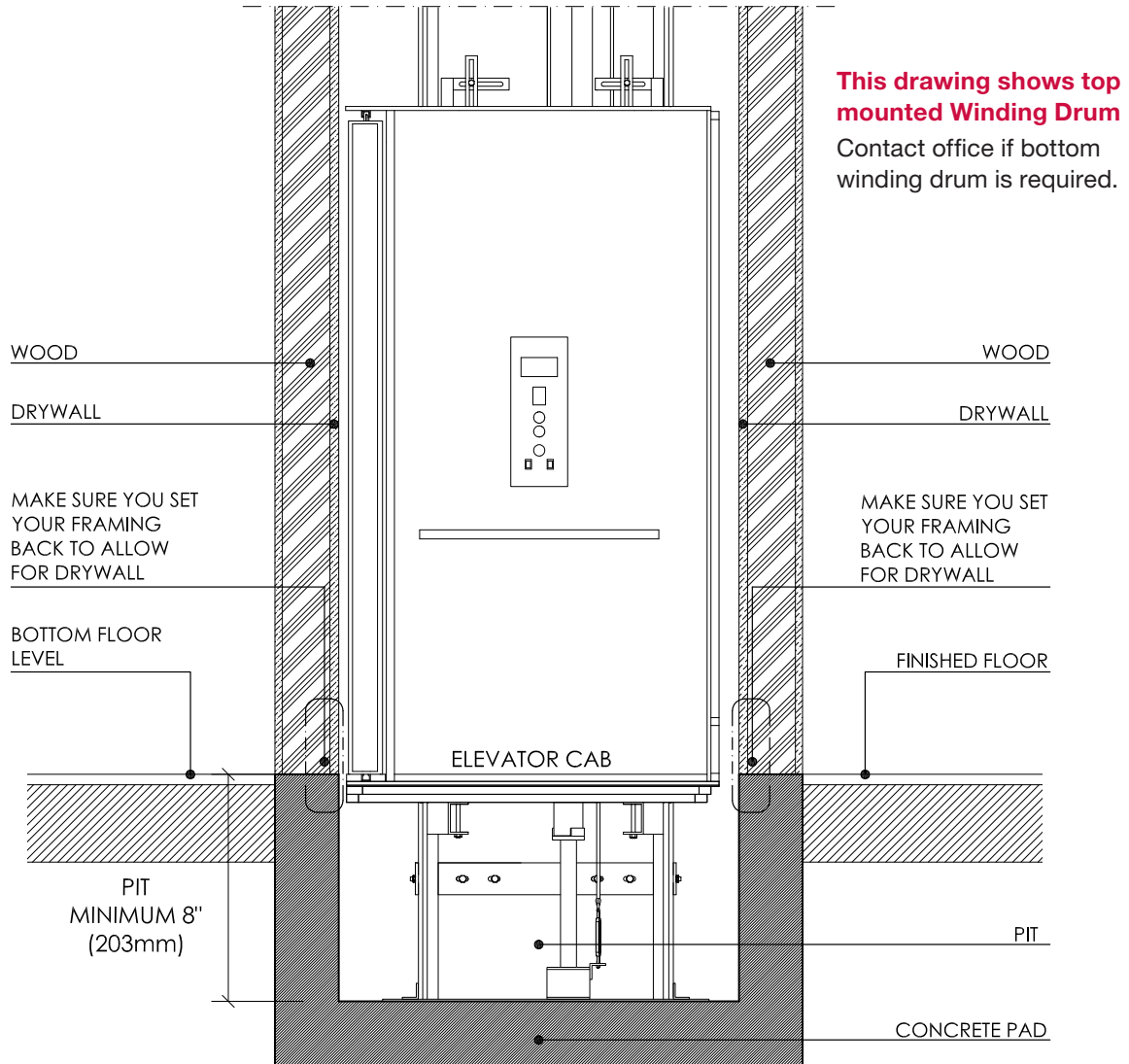

NOTES:

- 1 PIT FLOOR TO SUPPORT LOAD OF 17.0 kN OR 3800 lbs (DOUBLED FOR IMPACT).
- 2 PIT TO BE LEVEL, DRY AND FREE OF DEBRIS.
- 3 PIT MUST BE THE SAME WIDTH AND LENGTH AS THE HOISTWAY.
- 4 PIT MINIMUM 8" (203mm) UNLESS OTHERWISE INDICATED ON GENERAL LAYOUT.
- 5 BASED ON TOP MOUNTED WINDING DRUM.



RAIL BRACKET DETAIL ROPED

This drawing shows top mounted Winding Drum

Contact office if bottom winding drum is required.

27" D.B.G
(686)

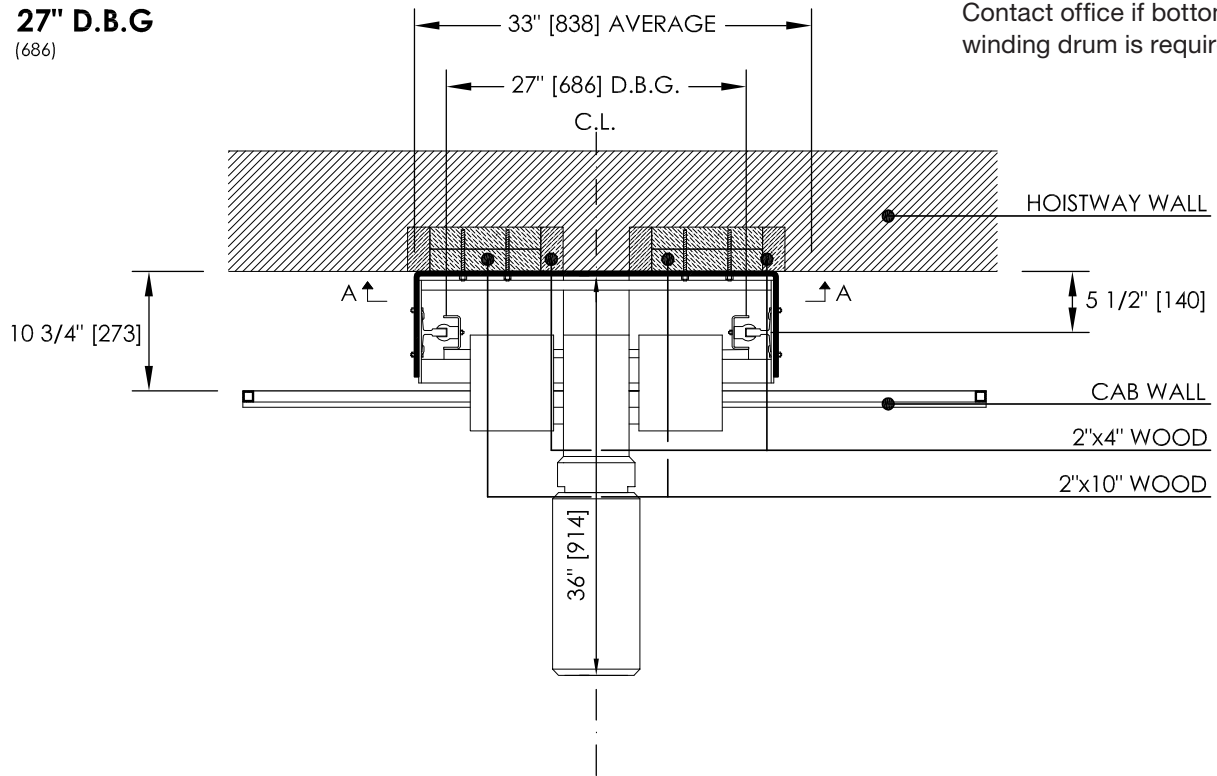

SECTION A-A
MOUNTING HOLE
LOCATIONS

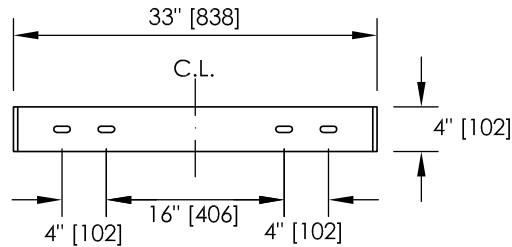

CRITICAL DIMENSIONS SHOWN BELOW ARE CORRECT FOR INSTALLATION PURPOSES:

- 1 WALL TO CENTRE OF RAIL = 5 1/2" (140mm)
- 2 WALL TO CAB = 10 3/4" (273mm)
- 3 BASED ON TOP MOUNTED WINDING DRUM.



RAIL FORCES

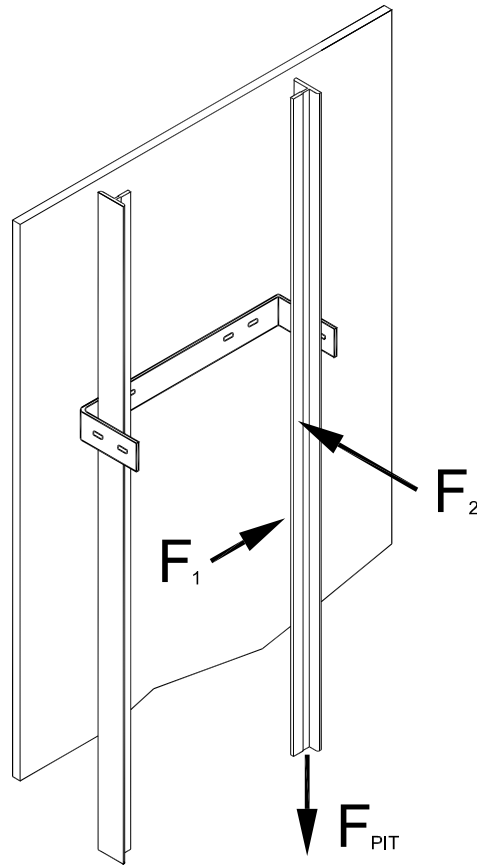

LOAD	DESCRIPTION	LB _r [KN]
F_{PIT}	Load Imposed on Pit Floor (Including Impact)	3825 [17.0]
F_1	Force on Rail	225 [1.0]
F_2	Force on Rail	675 [3.0]



CONTROLLER ROOM

This drawing shows top mounted Winding Drum

Contact office if bottom winding drum is required.

TYPE 1 FRONT

30AMP DISCONNECT C/W
AUXILIARY CONTACT
230V, 1PH, 60HZ



CONTROLLER
17"Wx7"Dx24"H

15AMP DISCONNECT FUSE
120V, 1PH, 60HZ

GFCI DUPLEX RECEPTACLE

TYPE 2 LATERAL

CONTROLLER
17"Wx7"Dx24"H

30AMP DISCONNECT C/W
AUXILIARY CONTACT
230V, 1PH, 60HZ



15AMP DISCONNECT FUSE
120V, 1PH, 60HZ

GFCI DUPLEX RECEPTACLE

TYPE 3 REMOTE



REMOTE

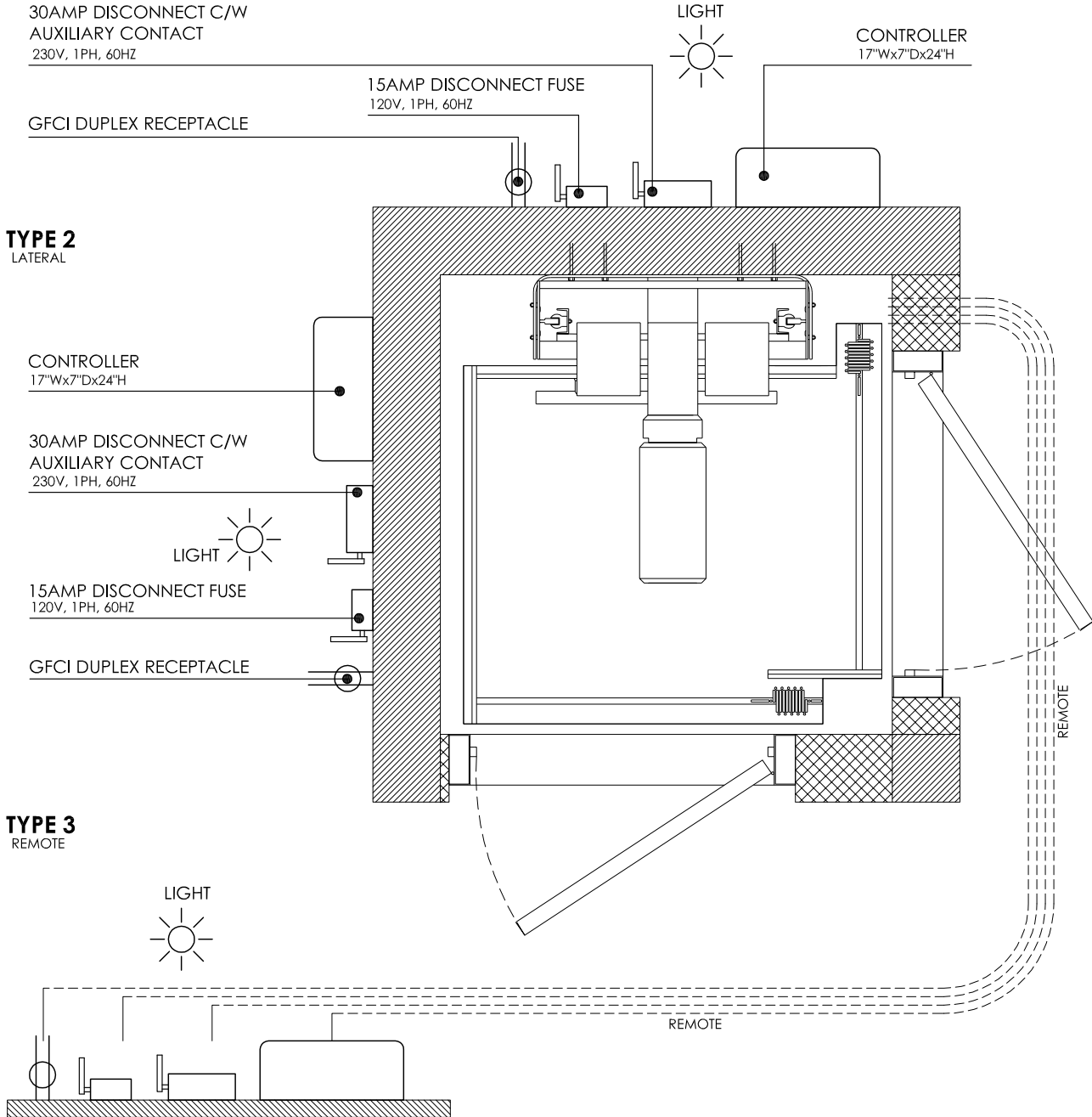

NOTES:

- 1 MINIMUM CONTROLLER ROOM HEIGHT SHALL BE 6'7" (2000MM)
- 2 1M (1000MM) CLEARANCE IN FRONT OF LIVE PANEL IS REQUIRED.
- 3 BASED ON TOP MOUNTED WINDING DRUM.



HOME ELEVATOR SAFETY CLEARANCE – ¾" x 4" RULE

The Safety Code for Elevators and Escalators ASME A17.1 or CSA B44, in Canada, Section 5.3 Private Residence Elevators is the basis for the safe design, construction and operation of home or residential elevators.

According to the Safety Code, the following items mandate the maximum hoistway door clearances (see drawings):

- **Section 5.3.1.7.2** Clearance between Hoistway Doors and Landing Sills states that the distance between the hoistway face of the hoistway doors and the hoistway edge of the landing sill shall not exceed ¾" [19mm] for swinging doors and 2 ¼" [57mm] for sliding doors.
- **Section 5.3.1.8.3** Clearance between Hoistway Doors and Car Doors or Gates stipulates that the distance between the hoistway face of the landing door or gate must reject a 4" [102mm] diameter ball at all points.

NOTE:

Some commercial metal door frames and masonry or concrete block shafts often create ¾" and 4" rule violations.

Recommendations:

Utilize solid doors since hollow doors do not provide the pull-out force required by code for the door locks. 1 ¾" thick solid core door should be used in lieu of a standard 1 ½" door.

IMPORTANT:

- If the landing door has a pattern on the inside of the hoistway, measure the ¾" setback from the deeper part of the door to the landing sill.
- The ¾" setback is only applicable when the car doors are bi-fold, 2 or 3-speed sliding doors.

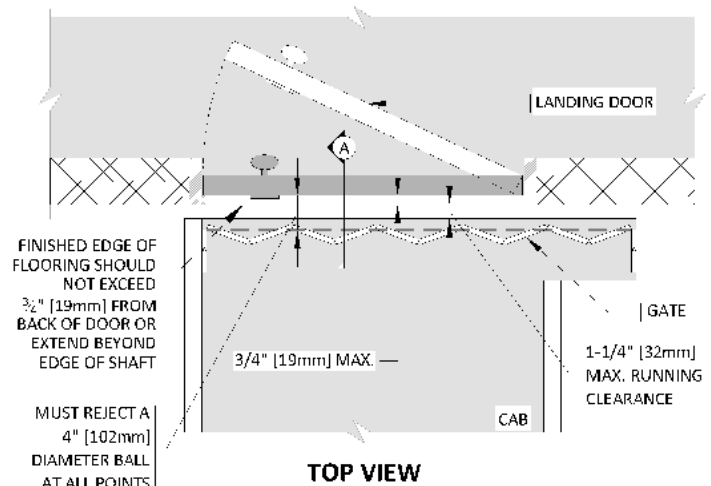
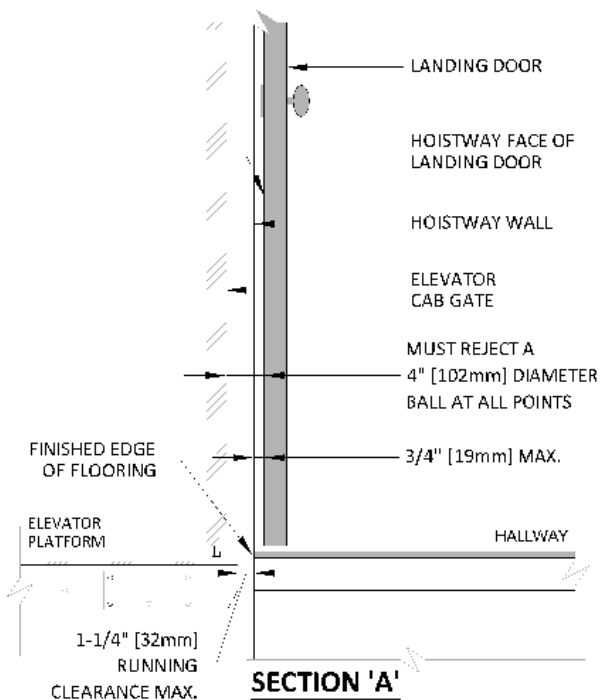

NOTE:

An out-of-plumb shaft will greatly affect running clearances and impair the Code Compliance Issues.

This is a code requirement. FEDERAL ELEVATOR is taking all measures and steps to ensure safety in the use of your elevator equipment. We have made it a policy to acquaint all Users/Owners, Architects, Developers, Builders and Contractors of this Code requirement and that they must duly comply to.



TYPE A

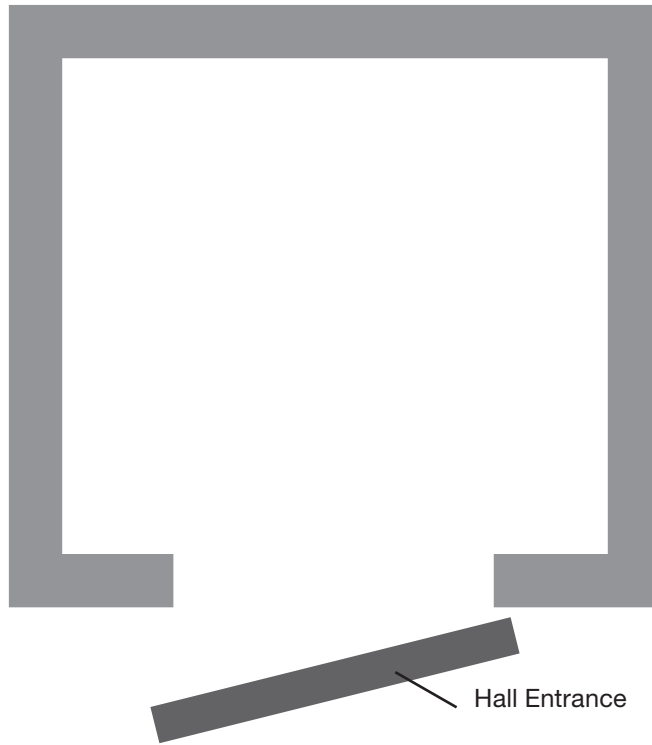

ONE POINT OF ENTRY ON ALL LEVELS

Cab Gate options:



Accordion Doors

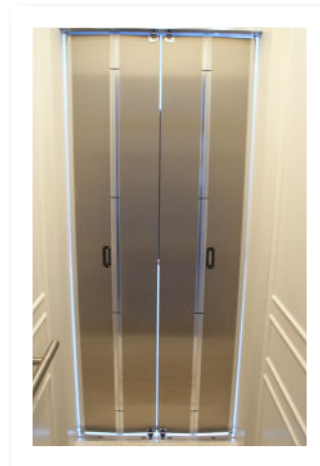

Bifold Doors

* Please contact us directly for dimensions with this door option



TYPE A RIGHT ACCORDION GATE

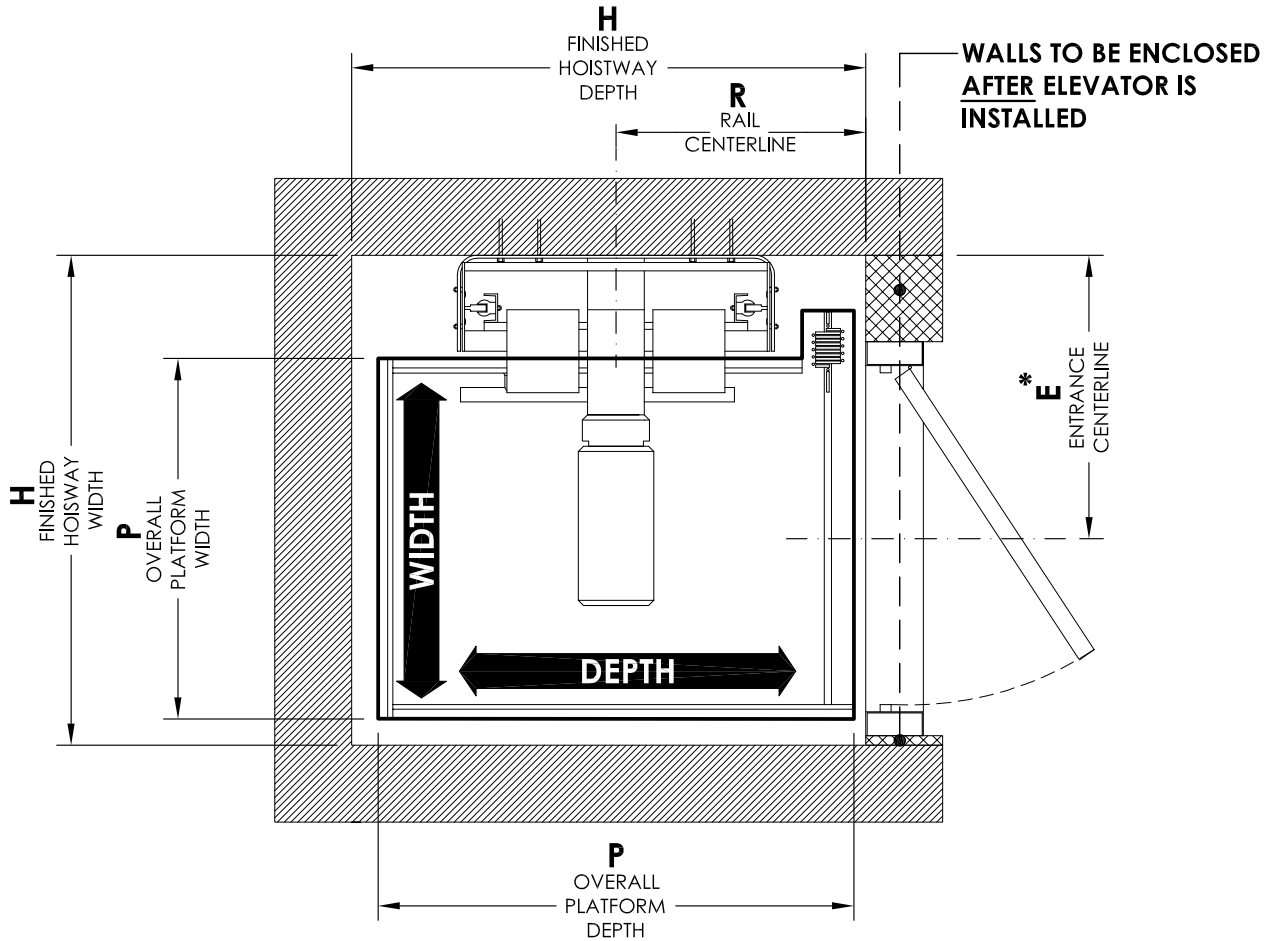

Cab Size (Width X Depth)	40" x 48" 1016mm x 1219mm	40" x 54" 1016mm x 1372mm	42" x 60" 1067mm x 1524mm	44" x 54" 1118mm x 1372mm
Finished Hoistway (H) Width x Depth	55 1/8" x 53 1/2" (1400 x 1359)	55 1/8" x 59 1/2" (1400 x 1511)	55 5/8" x 65 1/2" (1413 x 1664)	58 1/4" x 59 1/2" (1480 x 1511)
Overall Platform (P) Width x Depth	42 3/8" x 49 1/2" (1076 x 1257)	42 3/8" x 55 1/2" (1076 x 1410)	42 7/8" x 61 1/2" (1089 x 1562)	45 1/2" x 55 1/2" (1156 x 1410)
Entrance Centerline * (E1) (E2)	21 1/2" (546) 30 1/4" (768)	21 1/2" (546) 30 1/4" (768)	21 1/2" (546) 30 1/4" (768)	21 1/2" (546) 33 3/4" (848)
Rail Centerline (R)	26" (660)	29" (737)	32" (813)	29" (737)

* ENTRANCE CENTRELINE NOTES:

- FEDERAL ELEVATOR DOES NOT ACCEPT RESPONSIBILITY FOR THESE DIMENSIONS AS THEY WILL VARY DEPENDING ON HOW PLUMB AND STRAIGHT THE HOISTWAY HAS BEEN CONSTRUCTED.
- BARRICADES SHALL BE PROVIDED OUTSIDE EVERY OPENING TO HOISTWAY WHILE ELEVATOR IS BEING INSTALLED. BARRICADES SHALL BE ERECTED, MAINTAINED AND REMOVED BY OTHERS WHEN INSTALLATION WORK IS COMPLETE. THIS IS FOR SAFETY OF OTHER TRADES AND BUILDING OCCUPANTS.
- HALL ENTRANCES TO BE ENCLOSED **AFTER** ELEVATOR IS INSTALLED.



TYPE A LEFT ACCORDION GATE

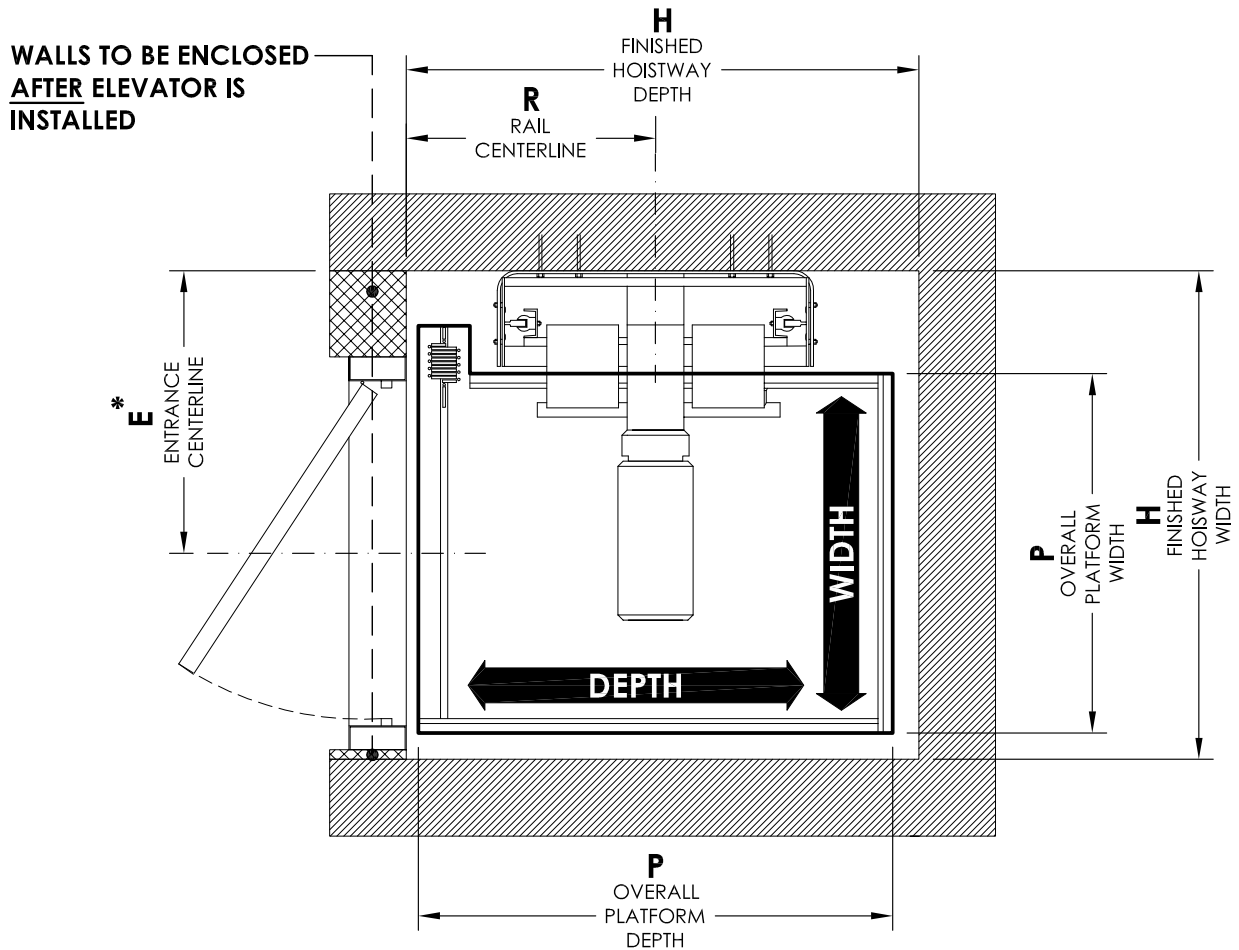

Cab Size (Width X Depth)	40" x 48" 1016mm x 1219mm	40" x 54" 1016mm x 1372mm	42" x 60" 1067mm x 1524mm	44" x 54" 1118mm x 1372mm
Finished Hoistway (H) Width x Depth	55 1/8" x 53 1/2" (1400 x 1359)	55 1/8" x 59 1/2" (1400 x 1511)	55 5/8" x 65 1/2" (1413 x 1664)	58 1/4" x 59 1/2" (1480 x 1511)
Overall Platform (P) Width x Depth	42 3/8" x 49 1/2" (1076 x 1257)	42 3/8" x 55 1/2" (1076 x 1410)	42 7/8" x 61 1/2" (1089 x 1562)	45 1/2" x 55 1/2" (1156 x 1410)
Entrance Centerline * (E1) (E2)	21 1/2" (546) 30 1/4" (768)	21 1/2" (546) 30 1/4" (768)	21 1/2" (546) 30 1/4" (768)	21 1/2" (546) 33 3/8" (848)
Rail Centerline (R)	26" (660)	29" (737)	32" (813)	29" (737)

* ENTRANCE CENTRELINE NOTES:

- FEDERAL ELEVATOR DOES NOT ACCEPT RESPONSIBILITY FOR THESE DIMENSIONS AS THEY WILL VARY DEPENDING ON HOW PLUMB AND STRAIGHT THE HOISTWAY HAS BEEN CONSTRUCTED.
- BARRICADES SHALL BE PROVIDED OUTSIDE EVERY OPENING TO HOISTWAY WHILE ELEVATOR IS BEING INSTALLED. BARRICADES SHALL BE ERECTED, MAINTAINED AND REMOVED BY OTHERS WHEN INSTALLATION WORK IS COMPLETE. THIS IS FOR SAFETY OF OTHER TRADES AND BUILDING OCCUPANTS.
- HALL ENTRANCES TO BE ENCLOSED **AFTER** ELEVATOR IS INSTALLED.



TYPE A RIGHT BI-FOLD GATE

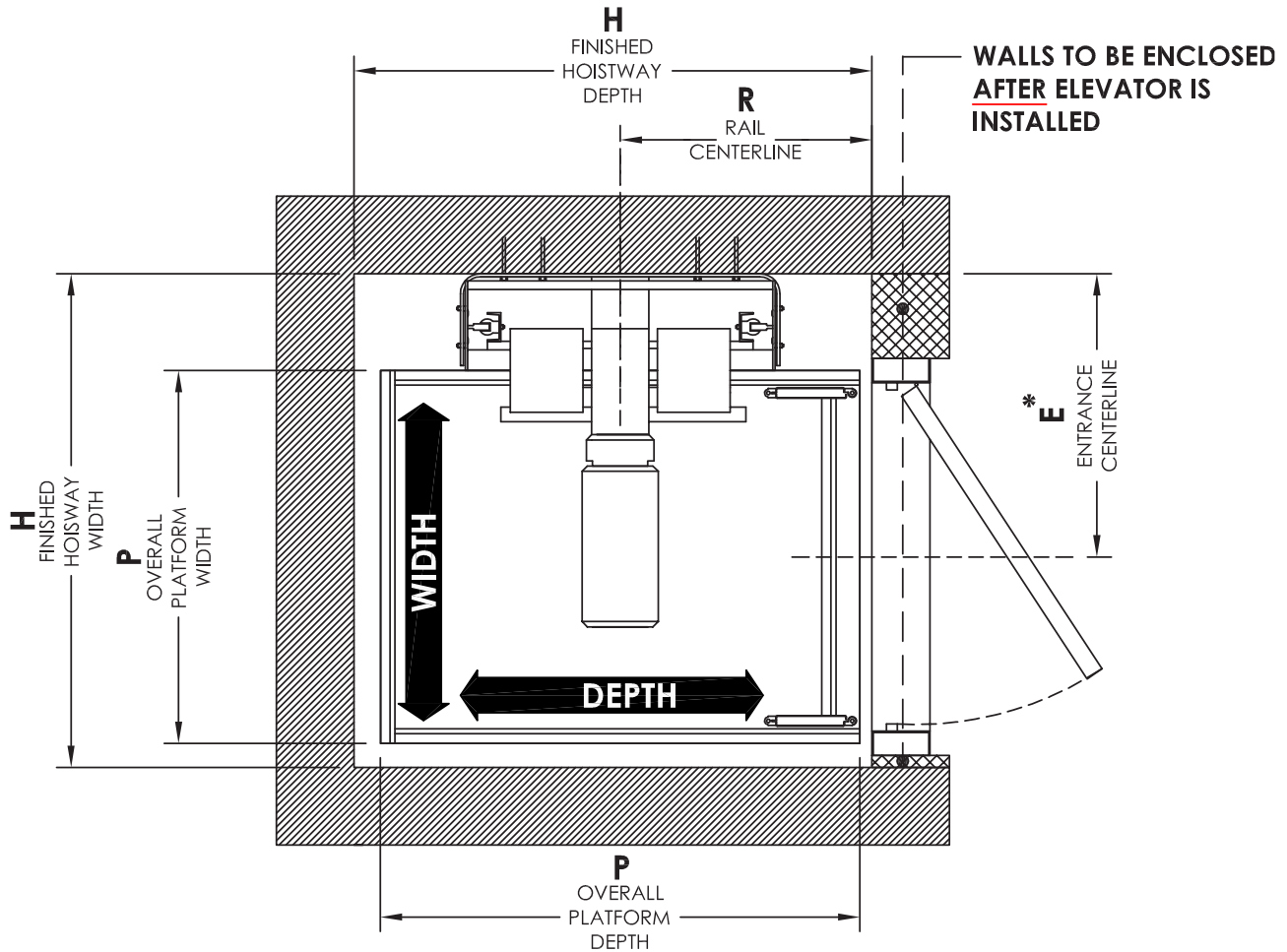

Cab Size (Width X Depth)	36" x 48" 915mm x 1220mm	36" x 54" 915mm x 1375mm	36" x 60" 915mm x 1525mm	40" x 54" 1015mm x 1375mm
Finished Hoistway (H) Width x Depth	51 3/4" x 53 1/2" (1314 x 1359)	51 3/4" x 59 1/2" (1314 x 1511)	51 3/4" x 65 1/2" (1314 x 1664)	54 3/4" x 59 1/2" (1391 x 1511)
Overall Platform (P) Width x Depth	38 1/2" x 49 1/2" (978 x 1257)	38 1/2" x 55 1/2" (978 x 1410)	38 1/2" x 61 1/2" (978 x 1562)	41 1/2" x 55 1/2" (1054 x 1410)
Entrance Centerline * (E)	30" (762)	30" (762)	30" (762)	30" (762)
Rail Centerline (R)	26" (660)	29" (737)	32" (813)	29" (737)

* ENTRANCE CENTRELINE NOTES:

- FEDERAL ELEVATOR DOES NOT ACCEPT RESPONSIBILITY FOR THESE DIMENSIONS AS THEY WILL VARY DEPENDING ON HOW PLUMB AND STRAIGHT THE HOISTWAY HAS BEEN CONSTRUCTED.
- BARRICADES SHALL BE PROVIDED OUTSIDE EVERY OPENING TO HOISTWAY WHILE ELEVATOR IS BEING INSTALLED. BARRICADES SHALL BE ERECTED, MAINTAINED AND REMOVED BY OTHERS WHEN INSTALLATION WORK IS COMPLETE. THIS IS FOR SAFETY OF OTHER TRADES AND BUILDING OCCUPANTS.
- HALL ENTRANCES TO BE ENCLOSED **AFTER** ELEVATOR IS INSTALLED.



TYPE A LEFT BI-FOLD GATE

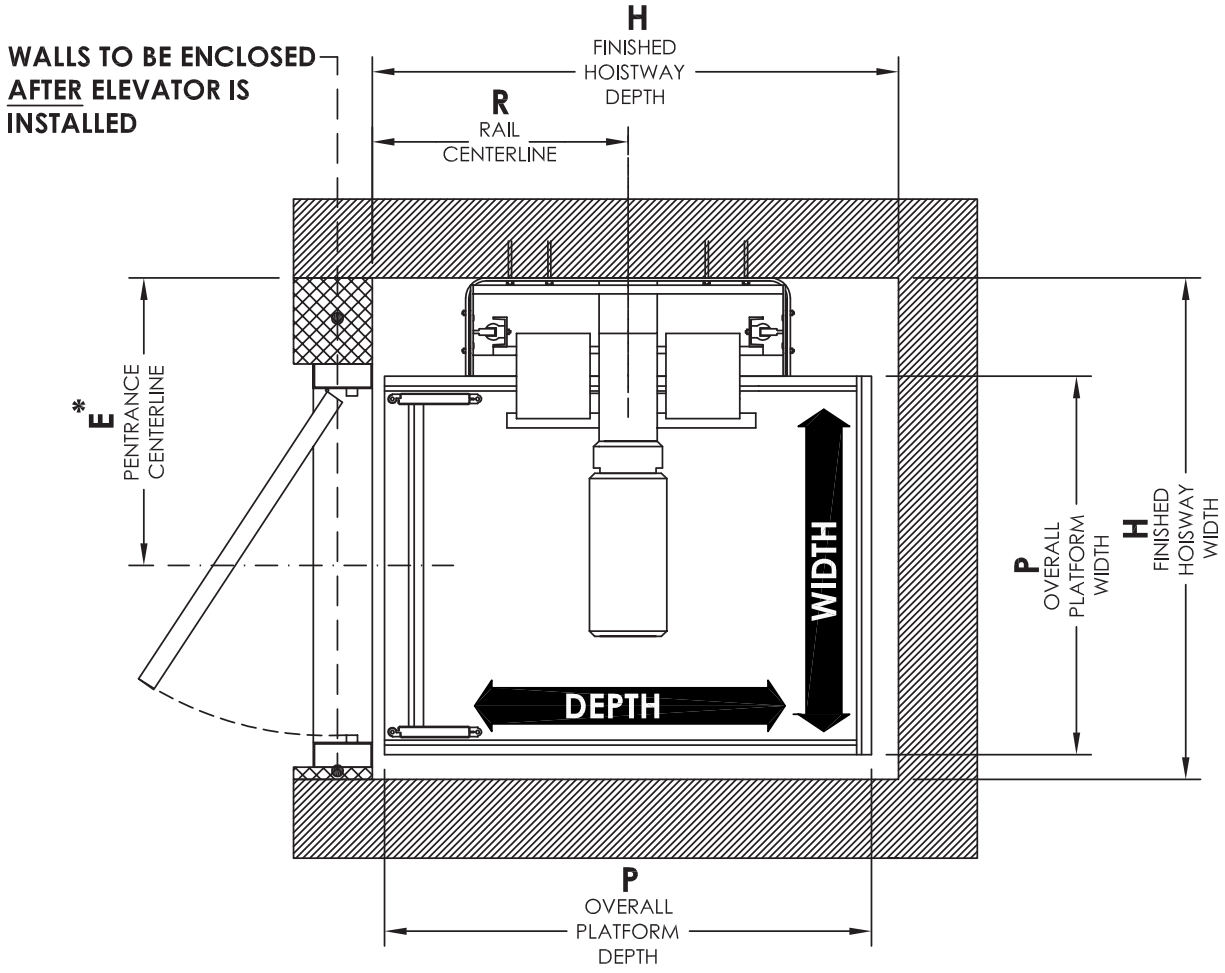

Cab Size (Width X Depth)	36" x 48" 915mm x 1220mm	36" x 54" 915mm x 1375mm	36" x 60" 915mm x 1525mm	40" x 54" 1015mm x 1375mm
Finished Hoistway (H) Width x Depth	51 3/4" x 53 1/2" (1314 x 1359)	51 3/4" x 59 1/2" (1314 x 1511)	51 3/4" x 65 1/2" (1314 x 1664)	54 3/4" x 59 1/2" (1391 x 1511)
Overall Platform (P) Width x Depth	38 1/2" x 49 1/2" (978 x 1257)	38 1/2" x 55 1/2" (978 x 1410)	38 1/2" x 61 1/2" (978 x 1562)	41 1/2" x 55 1/2" (1054 x 1410)
Entrance Centerline * (E)	30" (762)	30" (762)	30" (762)	30" (762)
Rail Centerline (R)	26" (660)	29" (737)	32" (813)	29" (737)

*** ENTRANCE CENTRELINE NOTES:**

- FEDERAL ELEVATOR DOES NOT ACCEPT RESPONSIBILITY FOR THESE DIMENSIONS AS THEY WILL VARY DEPENDING ON HOW PLUMB AND STRAIGHT THE HOISTWAY HAS BEEN CONSTRUCTED.
- BARRICADES SHALL BE PROVIDED OUTSIDE EVERY OPENING TO HOISTWAY WHILE ELEVATOR IS BEING INSTALLED. BARRICADES SHALL BE ERECTED, MAINTAINED AND REMOVED BY OTHERS WHEN INSTALLATION WORK IS COMPLETE. THIS IS FOR SAFETY OF OTHER TRADES AND BUILDING OCCUPANTS.
- HALL ENTRANCES TO BE ENCLOSED **AFTER** ELEVATOR IS INSTALLED.



TYPE B

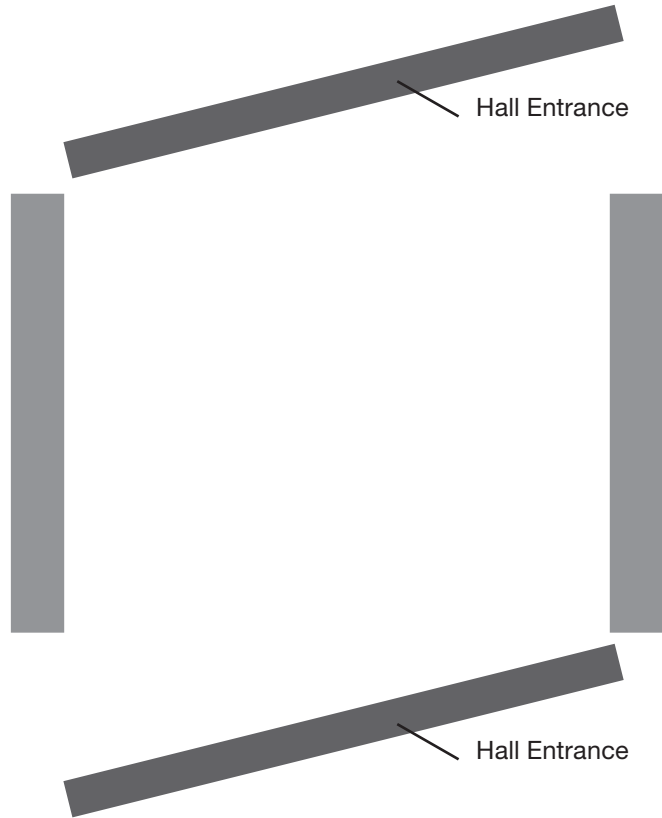

TWO POINTS OF ENTRY ON ALL LEVELS

Cab Gate options:



Accordion Doors

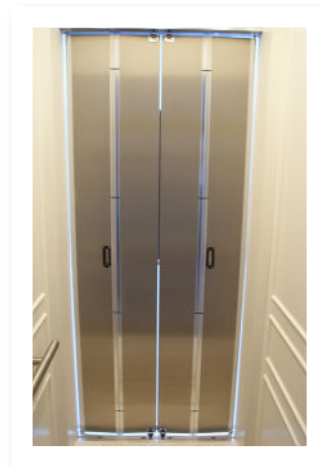

Bifold Doors

* Please contact us directly for dimensions with this door option



TYPE B ACCORDION GATE

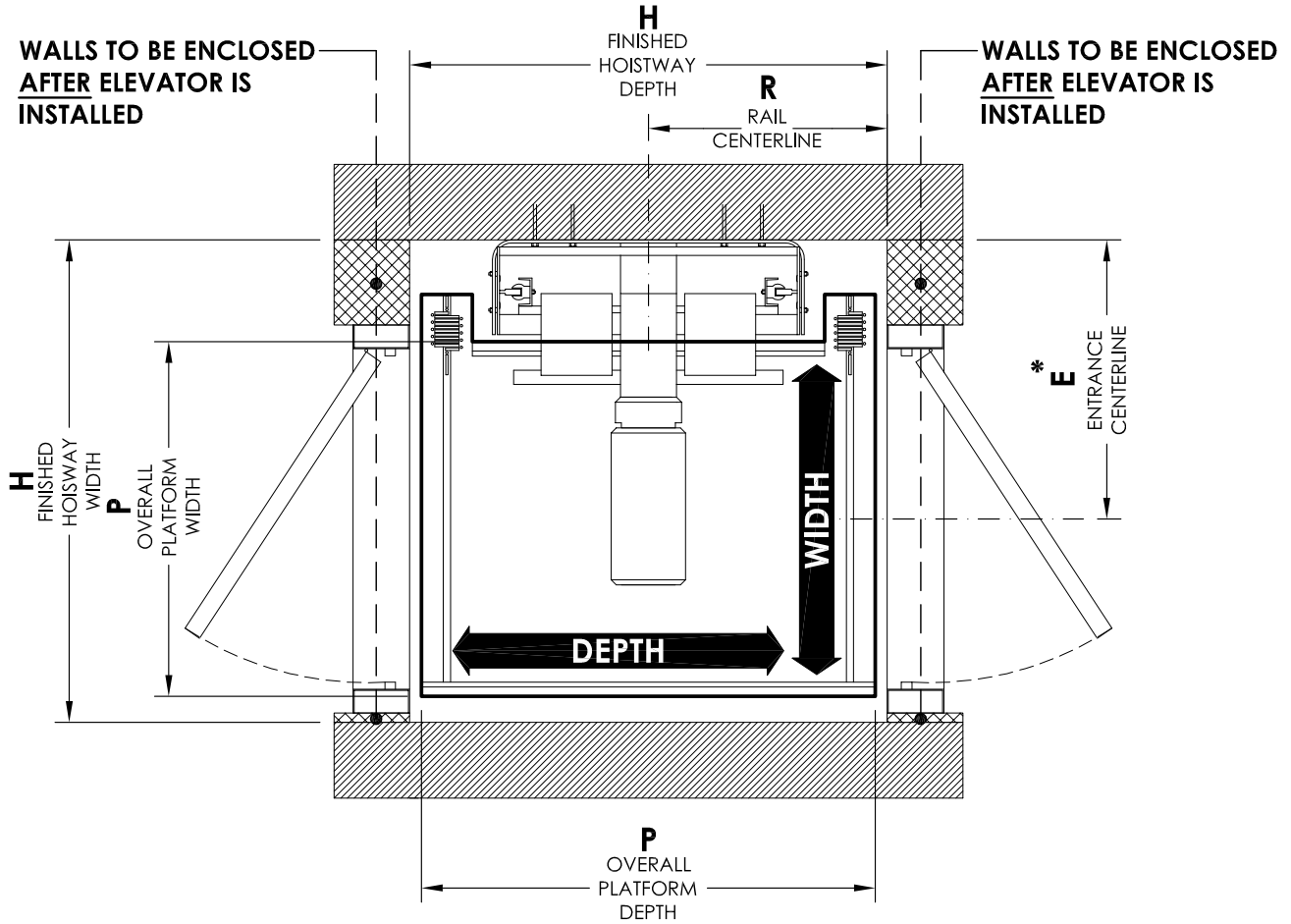

Cab Size (Width X Depth)	40" x 48" 1016mm x 1219mm	40" x 54" 1016mm x 1372mm	42" x 60" 1067mm x 1524mm	44" x 54" 1118mm x 1372mm
Finished Hoistway (H) Width x Depth	55 1/8" x 53 1/2" (1400 x 1359)	55 1/8" x 59 1/2" (1400 x 1511)	55 5/8" x 65 1/2" (1413 x 1664)	58 1/4" x 59 1/2" (1480 x 1511)
Overall Platform (P) Width x Depth	42 3/8" x 49 1/2" (1076 x 1257)	42 3/8" x 55 1/2" (1076 x 1410)	42 7/8" x 61 1/2" (1089 x 1562)	45 1/2" x 55 1/2" (1156 x 1410)
Entrance Centerline * (E1) (E2)	22" (559) 30 3/4" (781)	22" (559) 30 3/4" (781)	22" (559) 30 3/4" (781)	22" (559) 30 3/4" (781)
Rail Centerline (R)	26" (660)	29" (737)	32" (813)	29" (737)

* ENTRANCE CENTRELINE NOTES:

- FEDERAL ELEVATOR DOES NOT ACCEPT RESPONSIBILITY FOR THESE DIMENSIONS AS THEY WILL VARY DEPENDING ON HOW PLUMB AND STRAIGHT THE HOISTWAY HAS BEEN CONSTRUCTED.
- BARRICADES SHALL BE PROVIDED OUTSIDE EVERY OPENING TO HOISTWAY WHILE ELEVATOR IS BEING INSTALLED. BARRICADES SHALL BE ERECTED, MAINTAINED AND REMOVED BY OTHERS WHEN INSTALLATION WORK IS COMPLETE. THIS IS FOR SAFETY OF OTHER TRADES AND BUILDING OCCUPANTS.
- HALL ENTRANCES TO BE ENCLOSED **AFTER** ELEVATOR IS INSTALLED.



TYPE B BI-FOLD GATE

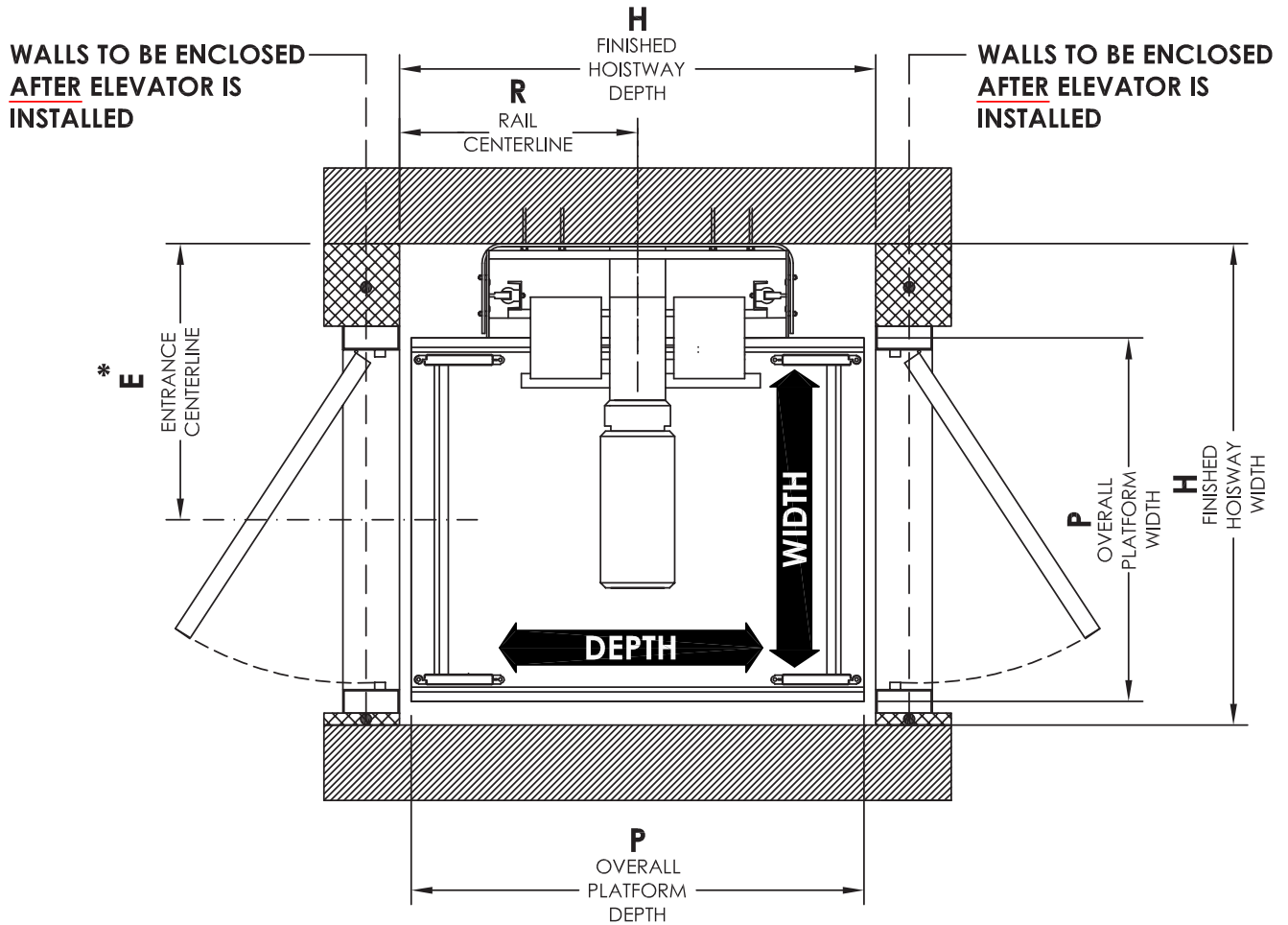

Cab Size (Width X Depth)	36" x 48" 915mm x 1220mm	36" x 54" 915mm x 1372mm	36" x 60" 915mm x 1525mm	40" x 54" 1015mm x 1372mm
Finished Hoistway (H) Width x Depth	51 3/4" x 50 1/2" (1314 x 1283)	51 3/4" x 56 1/2" (1314 x 1435)	51 3/4" x 62 1/2" (1314 x 1588)	54 3/4" x 56 1/2" (1391 x 1435)
Overall Platform (P) Width x Depth	38 1/2" x 48" (978 x 1219)	38 1/2" x 54" (978 x 1372)	38 1/2" x 60" (978 x 1524)	41 1/2" x 54" (1054 x 1372)
Entrance Centerline * (E1)	30" (762)	30" (762)	30" (762)	30" (762)
Rail Centerline (R)	25 1/4" (654)	28 1/4" (730)	31 1/4" (806)	28 1/4" (730)

* ENTRANCE CENTRELINE NOTES:

- FEDERAL ELEVATOR DOES NOT ACCEPT RESPONSIBILITY FOR THESE DIMENSIONS AS THEY WILL VARY DEPENDING ON HOW PLUMB AND STRAIGHT THE HOISTWAY HAS BEEN CONSTRUCTED.
- BARRICADES SHALL BE PROVIDED OUTSIDE EVERY OPENING TO HOISTWAY WHILE ELEVATOR IS BEING INSTALLED. BARRICADES SHALL BE ERECTED, MAINTAINED AND REMOVED BY OTHERS WHEN INSTALLATION WORK IS COMPLETE. THIS IS FOR SAFETY OF OTHER TRADES AND BUILDING OCCUPANTS.
- HALL ENTRANCES TO BE ENCLOSED **AFTER** ELEVATOR IS INSTALLED.



TYPE C

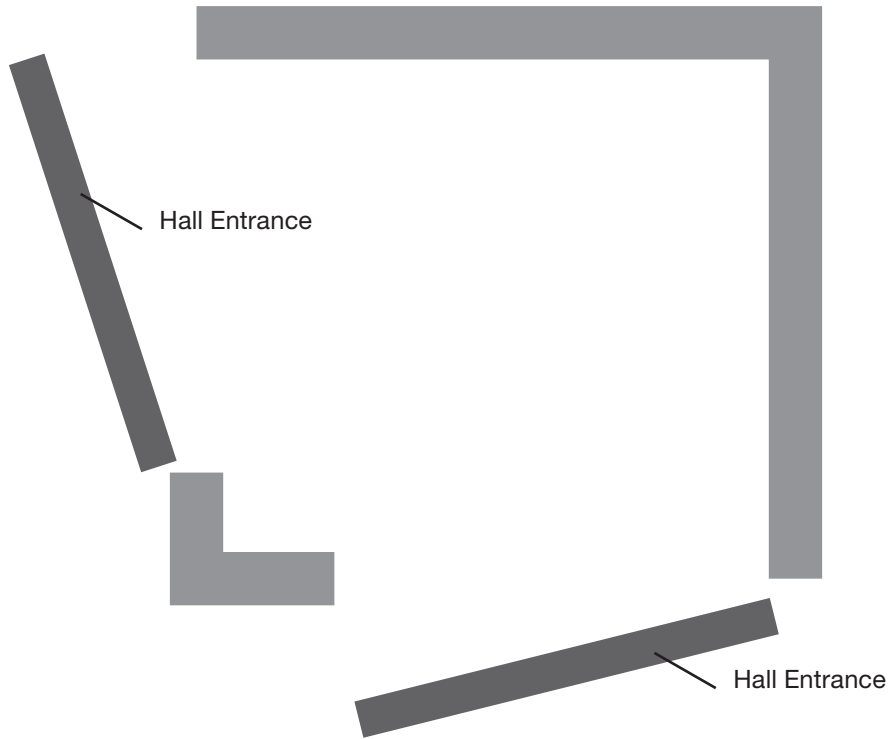

TWO POINTS OF ENTRY ON ALL LEVELS

Cab Gate options:



Accordion Doors

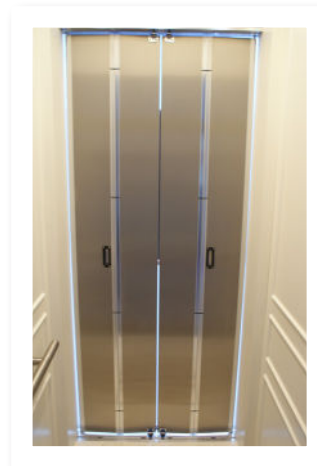

Bifold Doors

* Please contact us directly for dimensions with this door option



TYPE C ACCORDION GATE

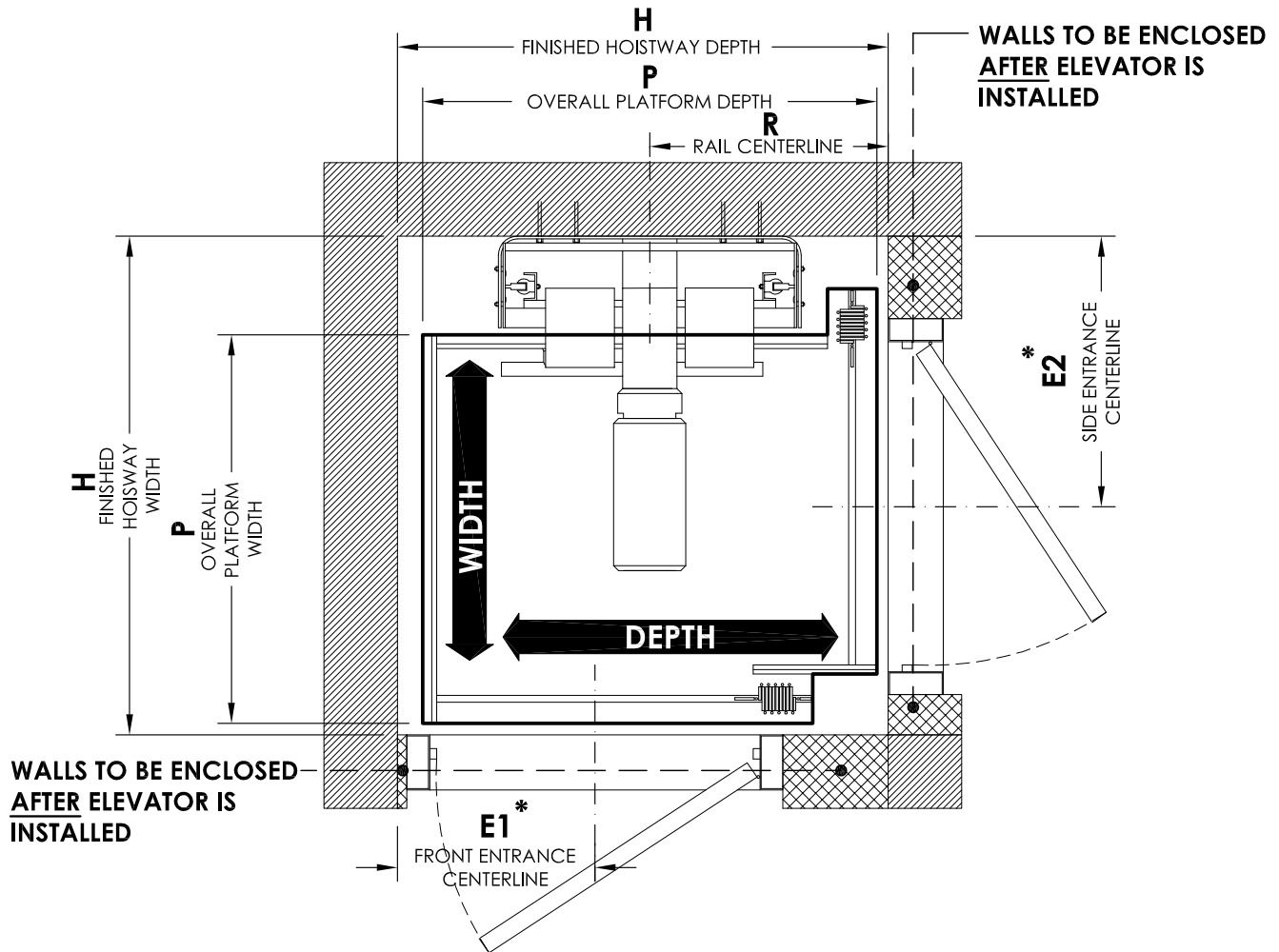

Cab Size (Width X Depth)	40" x 48" 1016mm x 1219mm	40" x 54" 1016mm x 1372mm	42" x 60" 1067mm x 1524mm	44" x 54" 1118mm x 1372mm
Finished Hoistway (H) Width x Depth	55 1/8" x 53 1/2" (1400 x 1359)	55 1/8" x 59 1/2" (1400 x 1511)	55 5/8" x 65 1/2" (1413 x 1664)	58 1/4" x 59 1/2" (1480 x 1511)
Overall Platform (P) Width x Depth	42 3/8" x 49 1/2" (1076 x 1257)	42 3/8" x 55 1/2" (1076 x 1410)	42 7/8" x 61 1/2" (1089 x 1562)	45 1/2" x 55 1/2" (1156 x 1410)
Entrance Centerline * (E1) (E2)	21 1/2" (546) 30 1/4" (768)	21 1/2" (546) 30 1/4" (768)	21 1/2" (546) 30 1/4" (768)	21 1/2" (546) 33 3/4" (848)
Rail Centerline (R)	26" (660)	29" (737)	32" (813)	29" (737)

* ENTRANCE CENTRELINE NOTES:

- FEDERAL ELEVATOR DOES NOT ACCEPT RESPONSIBILITY FOR THESE DIMENSIONS AS THEY WILL VARY DEPENDING ON HOW PLUMB AND STRAIGHT THE HOISWAY HAS BEEN CONSTRUCTED.
- BARRICADES SHALL BE PROVIDED OUTSIDE EVERY OPENING TO HOISWAY WHILE ELEVATOR IS BEING INSTALLED. BARRICADES SHALL BE ERECTED, MAINTAINED AND REMOVED BY OTHERS WHEN INSTALLATION WORK IS COMPLETE. THIS IS FOR SAFETY OF OTHER TRADES AND BUILDING OCCUPANTS.
- HALL ENTRANCES TO BE ENCLOSED **AFTER** ELEVATOR IS INSTALLED.



TYPE D

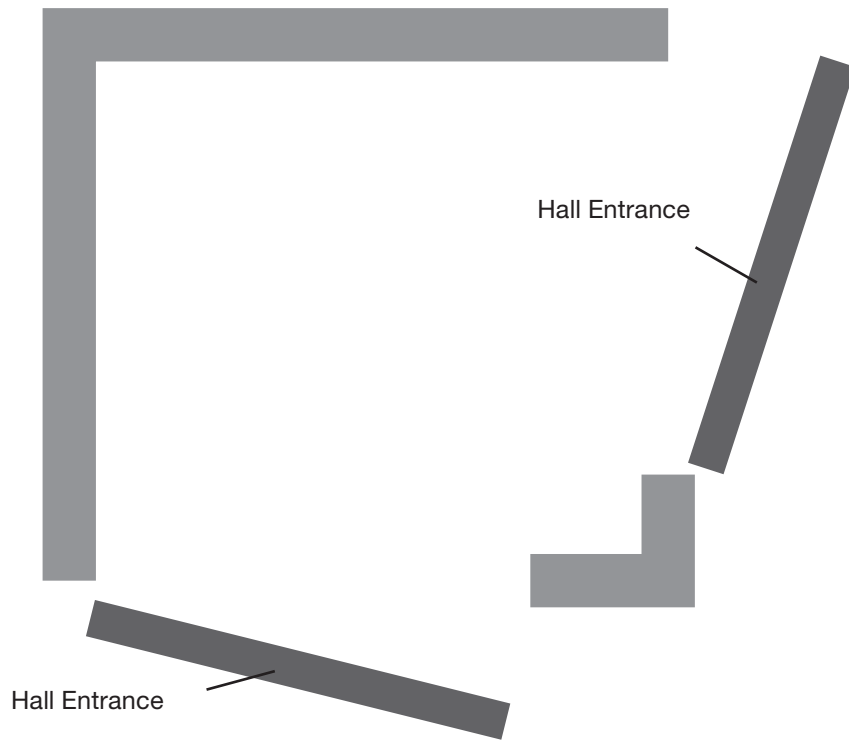

TWO POINTS OF ENTRY ON ALL LEVELS

Cab Gate options:



Accordion Doors

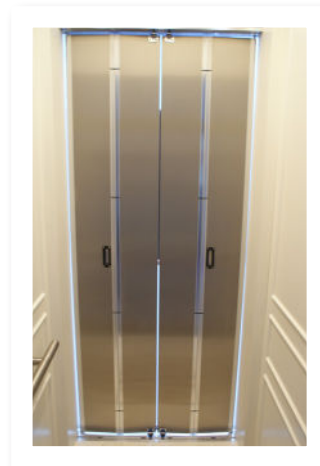

Bifold Doors

* Please contact us directly for dimensions with this door option



TYPE D ACCORDION GATE

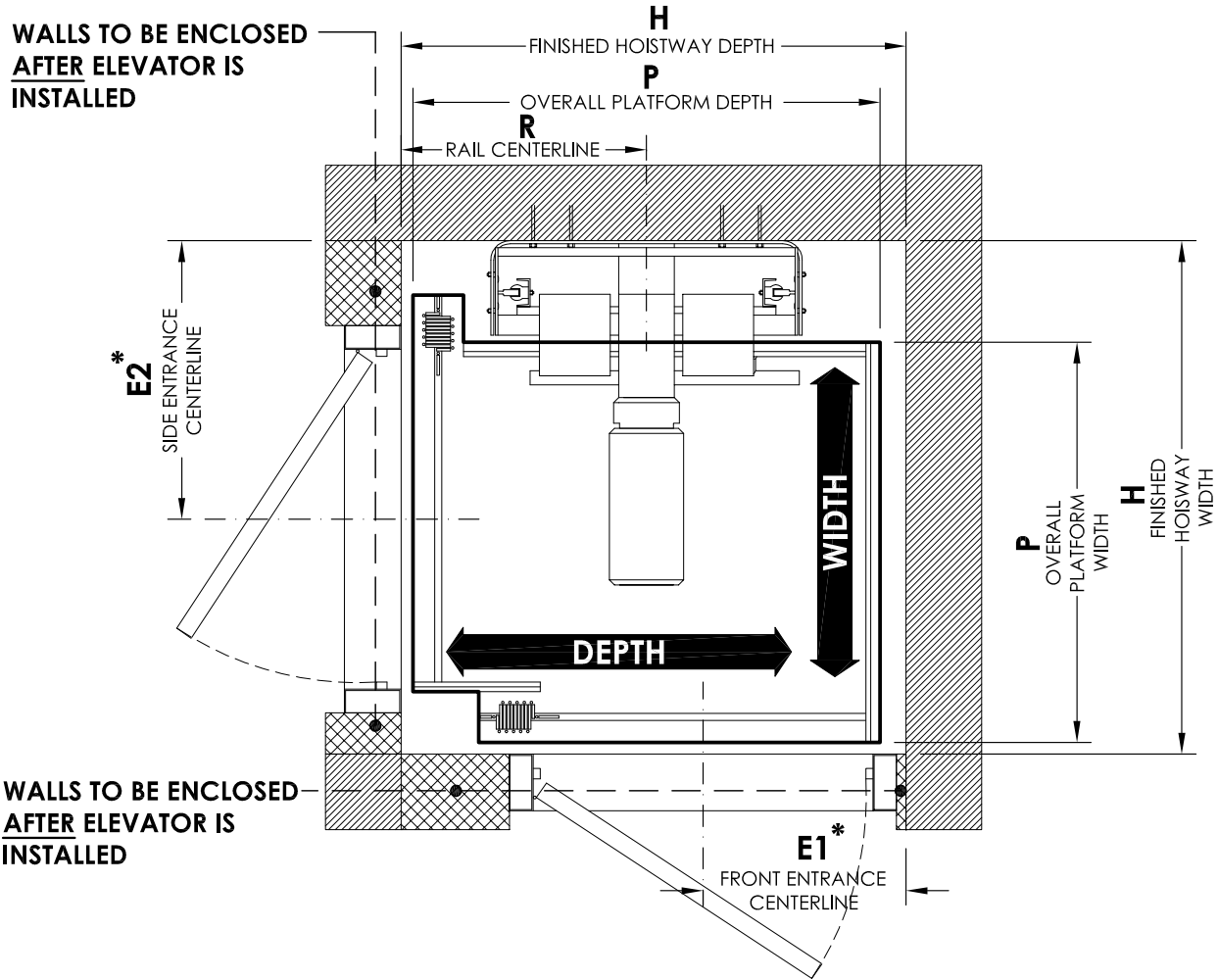

Cab Size (Width X Depth)	40" x 48" 1016mm x 1219mm	40" x 54" 1016mm x 1372mm	42" x 60" 1067mm x 1524mm	44" x 54" 1118mm x 1372mm
Finished Hoistway (H) Width x Depth	55 1/8" x 53 1/2" (1400 x 1359)	55 1/8" x 59 1/2" (1400 x 1511)	55 5/8" x 65 1/2" (1413 x 1664)	58 1/4" x 59 1/2" (1480 x 1511)
Overall Platform (P) Width x Depth	42 3/8" x 49 1/2" (1076 x 1257)	42 3/8" x 55 1/2" (1076 x 1410)	42 7/8" x 61 1/2" (1089 x 1562)	45 1/2" x 55 1/2" (1156 x 1410)
Entrance Centerline * (E1) (E2)	21 1/2" (546) 30 1/4" (768)	21 1/2" (546) 30 1/4" (768)	21 1/2" (546) 30 1/4" (768)	21 1/2" (546) 33 3/8" (848)
Rail Centerline (R)	26" (660)	29" (737)	32" (813)	29" (737)

* ENTRANCE CENTRELINE NOTES:

- FEDERAL ELEVATOR DOES NOT ACCEPT RESPONSIBILITY FOR THESE DIMENSIONS AS THEY WILL VARY DEPENDING ON HOW PLUMB AND STRAIGHT THE HOISTWAY HAS BEEN CONSTRUCTED.
- BARRICADES SHALL BE PROVIDED OUTSIDE EVERY OPENING TO HOISTWAY WHILE ELEVATOR IS BEING INSTALLED. BARRICADES SHALL BE ERECTED, MAINTAINED AND REMOVED BY OTHERS WHEN INSTALLATION WORK IS COMPLETE. THIS IS FOR SAFETY OF OTHER TRADES AND BUILDING OCCUPANTS.
- HALL ENTRANCES TO BE ENCLOSED **AFTER** ELEVATOR IS INSTALLED.



TYPE E

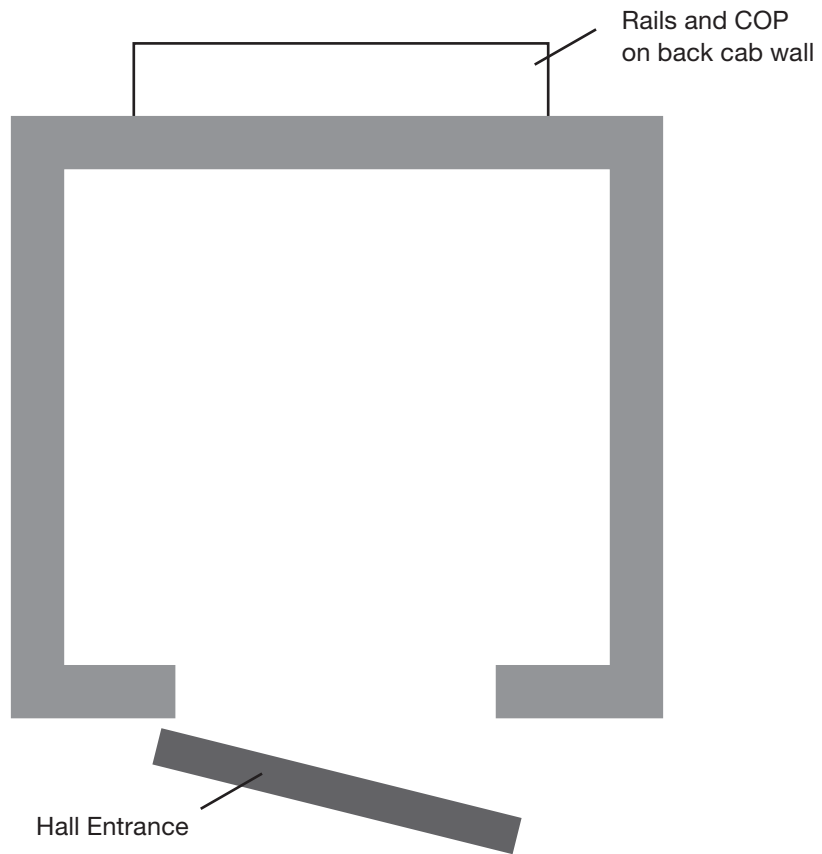

ONE POINT OF ENTRY
RAILS AND COP ON BACK WALL

Cab Gate options:



Accordion Doors

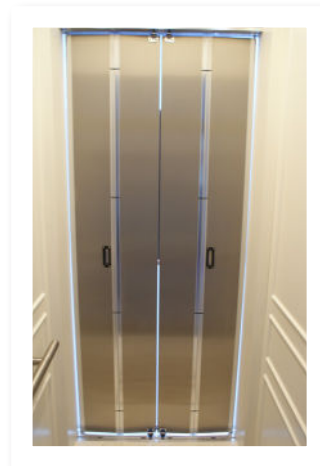

Bifold Doors

* Please contact us directly for dimensions with this door option



TYPE E ACCORDION GATE – CENTERED ENTRANCE

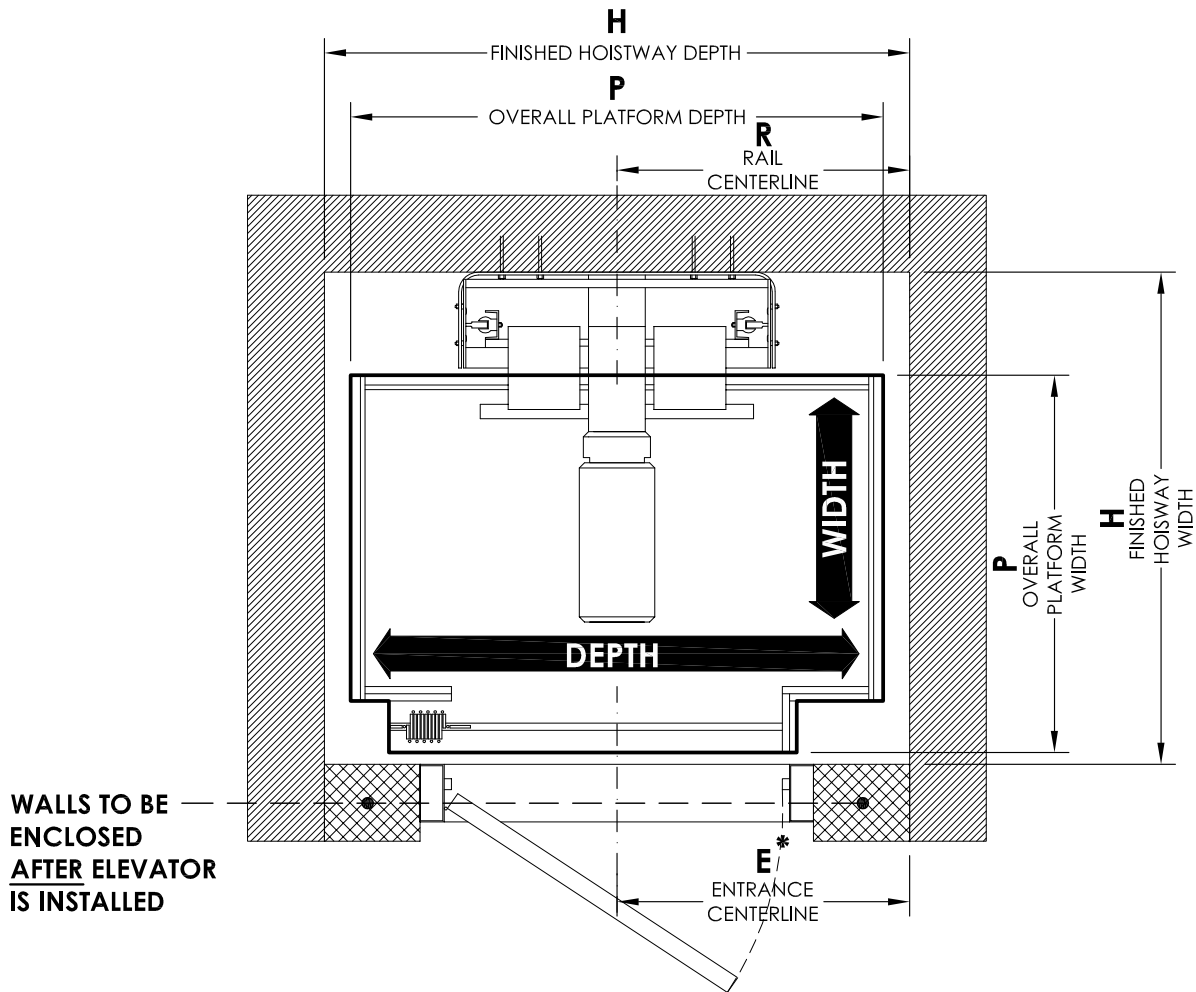

Cab Size (Width X Depth)	40" x 48" 1016mm x 1219mm	40" x 54" 1016mm x 1372mm	42" x 60" 1067mm x 1524mm	44" x 54" 1118mm x 1372mm
Finished Hoistway (H) Width x Depth	50 ¼" x 55" (1276 x 1397)	50 ¼" x 61" (1276 x 1549)	50 ¼" x 67" (1276 x 1702)	54 ¼" x 61" (1276 x 1549)
Overall Platform (P) Width x Depth	37 ½" x 49 ½" (953 x 1257)	37 ½" x 55 ½" (953 x 1410)	37 ½" x 61 ½" (953 x 1562)	41 ½" x 55 ½" (1054 x 1410)
Entrance Centerline * (E)	27 ½" (699)	30 ½" (775)	33 ½" (851)	30 ½" (775)
Rail Centerline (R)	27 ½" (699)	30 ½" (775)	33 ½" (851)	30 ½" (775)

* ENTRANCE CENTRELINE NOTES:

- FEDERAL ELEVATOR DOES NOT ACCEPT RESPONSIBILITY FOR THESE DIMENSIONS AS THEY WILL VARY DEPENDING ON HOW PLUMB AND STRAIGHT THE HOISTWAY HAS BEEN CONSTRUCTED.
- BARRICADES SHALL BE PROVIDED OUTSIDE EVERY OPENING TO HOISTWAY WHILE ELEVATOR IS BEING INSTALLED. BARRICADES SHALL BE ERECTED, MAINTAINED AND REMOVED BY OTHERS WHEN INSTALLATION WORK IS COMPLETE. THIS IS FOR SAFETY OF OTHER TRADES AND BUILDING OCCUPANTS.
- HALL ENTRANCES TO BE ENCLOSED **AFTER** ELEVATOR IS INSTALLED.



TYPE E LEFT ACCORDION GATE

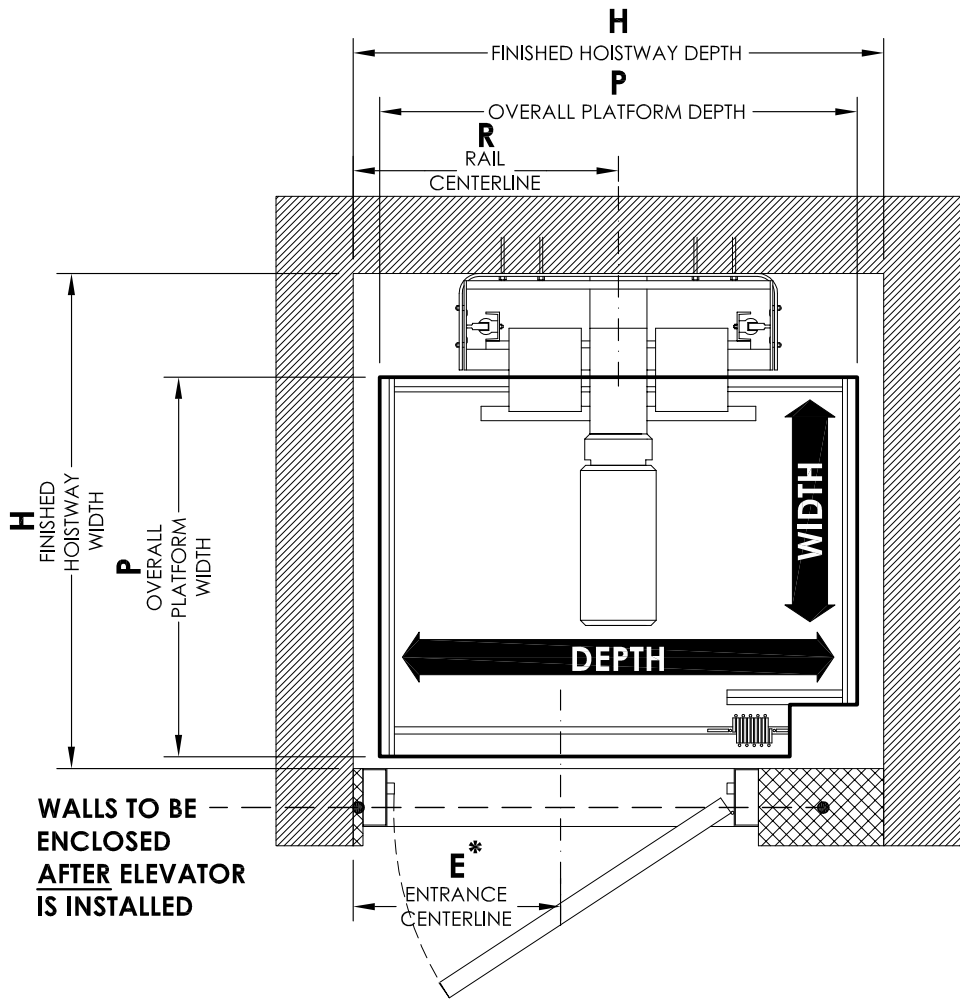

Cab Size (Width X Depth)	40" x 48" 1016mm x 1219mm	40" x 54" 1016mm x 1372mm	42" x 60" 1067mm x 1524mm	44" x 54" 1118mm x 1372mm
Finished Hoistway (H) Width x Depth	50 1/4" x 55" (1276 x 1397)	50 1/4" x 61" (1276 x 1549)	50 1/4" x 67" (1276 x 1702)	54 1/4" x 61" (1276 x 1549)
Overall Platform (P) Width x Depth	37 1/2" x 49 1/2" (953 x 1257)	37 1/2" x 55 1/2" (953 x 1410)	37 1/2" x 61 1/2" (953 x 1562)	41 1/2" x 55 1/2" (1054 x 1410)
Entrance Centerline * (E)	21 1/2" (546)	21 1/2" (546)	21 1/2" (546)	21 1/2" (546)
Rail Centerline (R)	27 1/2" (699)	30 1/2" (775)	33 1/2" (851)	30 1/2" (775)

* ENTRANCE CENTRELINE NOTES:

- FEDERAL ELEVATOR DOES NOT ACCEPT RESPONSIBILITY FOR THESE DIMENSIONS AS THEY WILL VARY DEPENDING ON HOW PLUMB AND STRAIGHT THE HOISTWAY HAS BEEN CONSTRUCTED.
- BARRICADES SHALL BE PROVIDED OUTSIDE EVERY OPENING TO HOISTWAY WHILE ELEVATOR IS BEING INSTALLED. BARRICADES SHALL BE ERECTED, MAINTAINED AND REMOVED BY OTHERS WHEN INSTALLATION WORK IS COMPLETE. THIS IS FOR SAFETY OF OTHER TRADES AND BUILDING OCCUPANTS.
- HALL ENTRANCES TO BE ENCLOSED **AFTER** ELEVATOR IS INSTALLED.



TYPE E RIGHT ACCORDION GATE

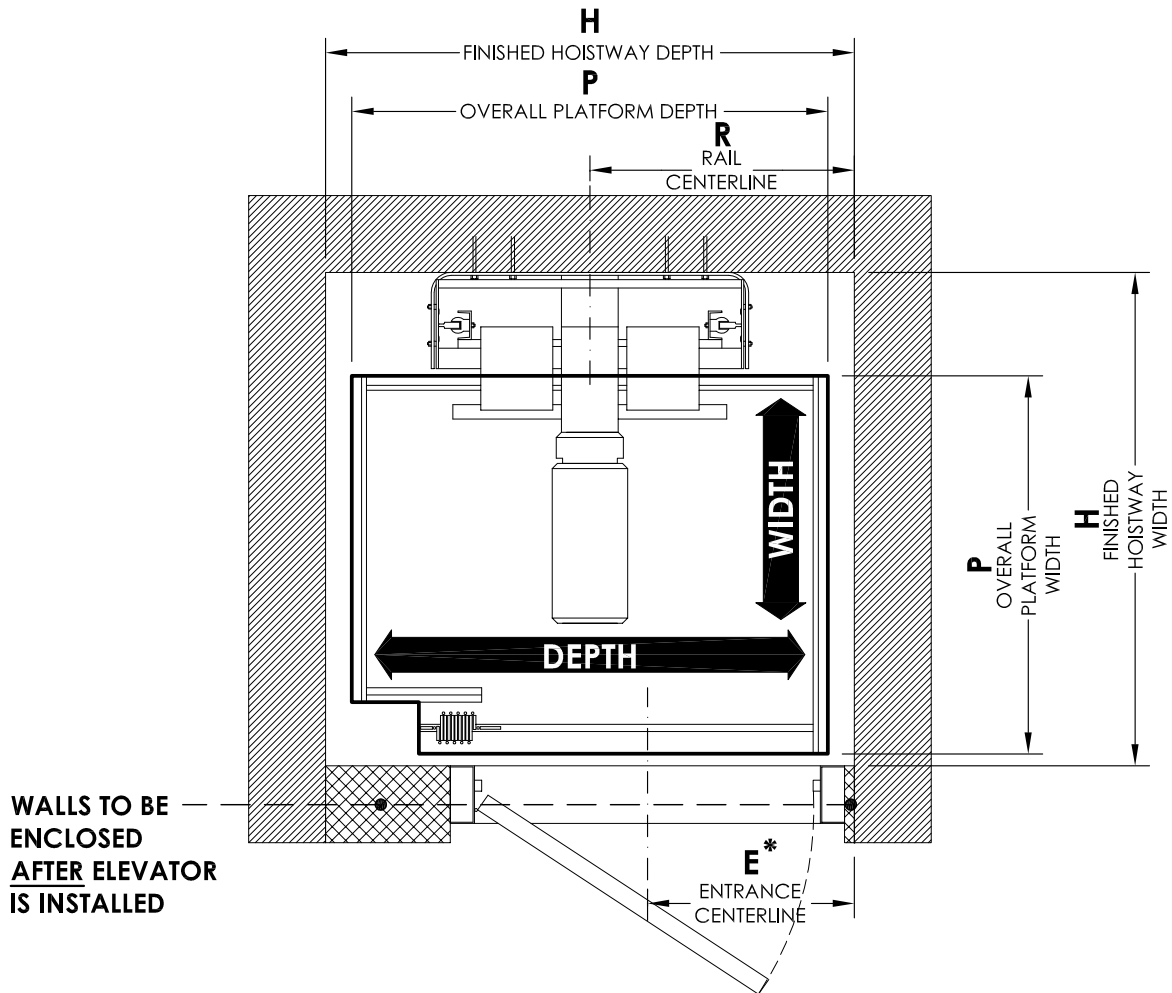

Cab Size (Width X Depth)	40" x 48" 1016mm x 1219mm	40" x 54" 1016mm x 1372mm	42" x 60" 1067mm x 1524mm	44" x 54" 1118mm x 1372mm
Finished Hoistway (H) Width x Depth	50 1/4" x 55" (1276 x 1397)	50 1/4" x 61" (1276 x 1549)	50 1/4" x 67" (1276 x 1702)	54 1/4" x 61" (1276 x 1549)
Overall Platform (P) Width x Depth	37 1/2" x 49 1/2" (953 x 1257)	37 1/2" x 55 1/2" (953 x 1410)	37 1/2" x 61 1/2" (953 x 1562)	41 1/2" x 55 1/2" (1054 x 1410)
Entrance Centerline * (E)	21 1/2" (546)	21 1/2" (546)	21 1/2" (546)	21 1/2" (546)
Rail Centerline (R)	27 1/2" (699)	30 1/2" (775)	33 1/2" (851)	30 1/2" (775)

* ENTRANCE CENTRELINE NOTES:

- FEDERAL ELEVATOR DOES NOT ACCEPT RESPONSIBILITY FOR THESE DIMENSIONS AS THEY WILL VARY DEPENDING ON HOW PLUMB AND STRAIGHT THE HOISTWAY HAS BEEN CONSTRUCTED.
- BARRICADES SHALL BE PROVIDED OUTSIDE EVERY OPENING TO HOISTWAY WHILE ELEVATOR IS BEING INSTALLED. BARRICADES SHALL BE ERECTED, MAINTAINED AND REMOVED BY OTHERS WHEN INSTALLATION WORK IS COMPLETE. THIS IS FOR SAFETY OF OTHER TRADES AND BUILDING OCCUPANTS.
- HALL ENTRANCES TO BE ENCLOSED **AFTER** ELEVATOR IS INSTALLED.



TYPE E BI-FOLD GATE - CENTERED ENTRANCE

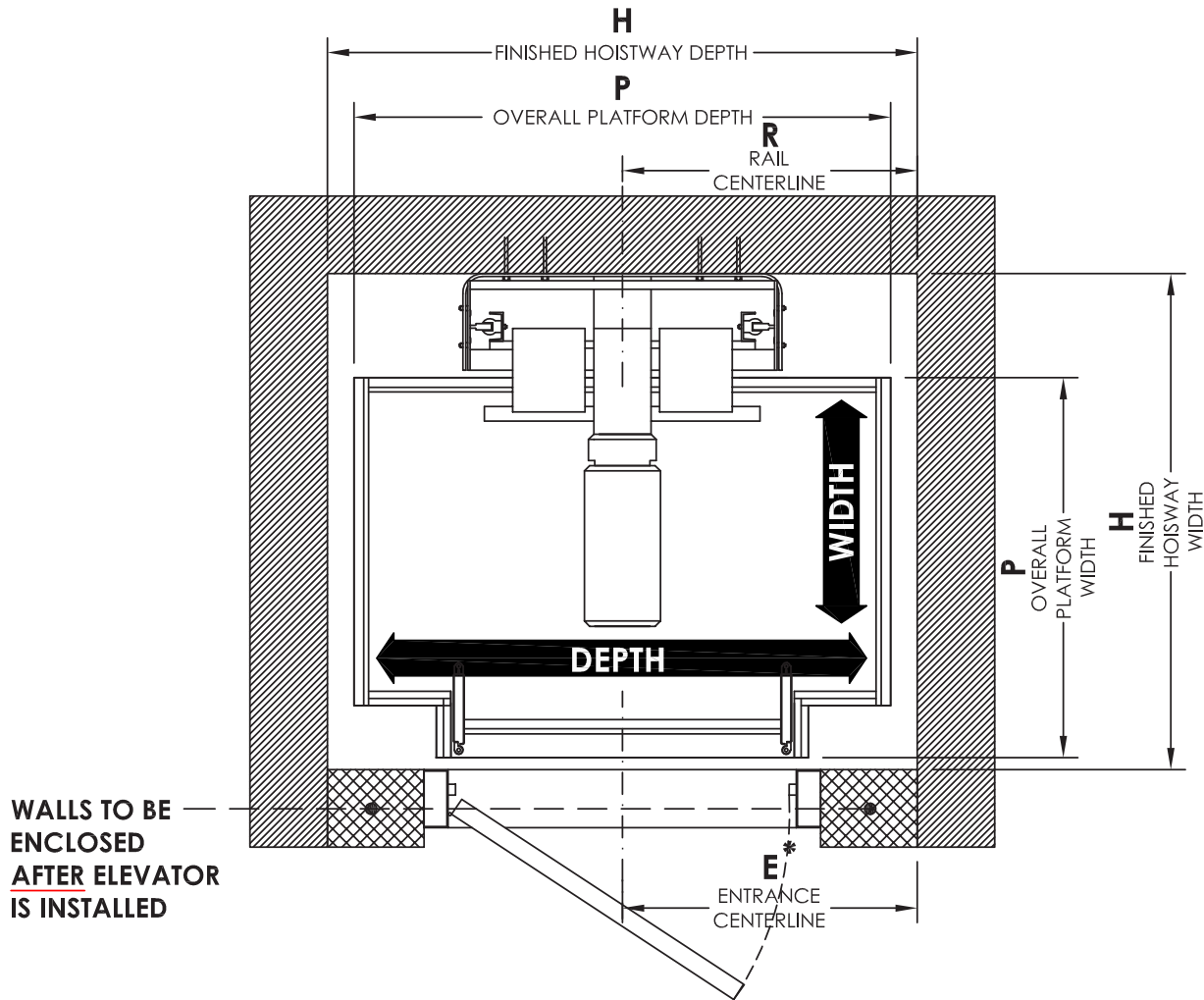

Cab Size (Width X Depth)	36" x 48" 915mm x 1220mm	36" x 54" 915mm x 1375mm	36" x 60" 915mm x 1525mm	40" x 54" 1015mm x 1375mm
Finished Hoistway (H) Width x Depth	55" x 55" (1397 x 1397)	61" x 55" (1549 x 1397)	67" x 55" (1702 x 1397)	61" x 59" (1549 x 1499)
Overall Platform (P) Width x Depth	49 1/2" x 43" (1257 x 1092)	55 1/2" x 43" (1410 x 1092)	61 1/2" x 43" (1562 x 1092)	55 1/2" x 47" (1410 x 1194)
Entrance Centerline * (E)	21 1/2" (546)	30 1/2" (775)	33 1/2" (851)	30 1/2" (775)
Rail Centerline (R)	27 1/2" (699)	30 1/2" (775)	33 1/2" (851)	30 1/2" (775)

* ENTRANCE CENTRELINE NOTES:

- FEDERAL ELEVATOR DOES NOT ACCEPT RESPONSIBILITY FOR THESE DIMENSIONS AS THEY WILL VARY DEPENDING ON HOW PLUMB AND STRAIGHT THE HOISWAY HAS BEEN CONSTRUCTED.
- BARRICADES SHALL BE PROVIDED OUTSIDE EVERY OPENING TO HOISWAY WHILE ELEVATOR IS BEING INSTALLED. BARRICADES SHALL BE ERCTED, MAINTAINED AND REMOVED BY OTHERS WHEN INSTALLATION WORK IS COMPLETE. THIS IS FOR SAFETY OF OTHER TRADES AND BUILDING OCCUPANTS.
- HALL ENTRANCES TO BE ENCLOSED **AFTER** ELEVATOR IS INSTALLED.

DESIGN | ENGINEER | MANUFACTURE | INSTALL



Federal Elevator

1090 Lorimar Drive
Mississauga, ON L5S 2A1

Tel 905.458.4015

Toll 1.888.785.5438



www.federalelevator.com